

Miele

Operating and Installation Instructions



Fridge-Freezer Combination KFN 9755 iDE

To prevent accidents
and machine damage
read these instructions

before

installation or use.

en - US, CA

M.-Nr. 07 938 590

Contents

IMPORTANT SAFETY INSTRUCTIONS	4
Guide to the Fridge-Freezer combination	8
Before use	10
Before using for the first time	10
Turning the appliance on/Off	11
Safety lock	11
Preparing your Appliance for an Extended Vacation	12
Setting the temperature	13
Setting the temperature in the refrigerator and freezer sections	13
Temperature displays	14
Alarm	16
Door alarm	16
Turning the alarm off	16
Using the Super and DynaCool functions	17
Super function	17
DynaCool 	18
Using the refrigerator efficiently	19
Different storage zones	19
Using the freezer efficiently	20
Freezing food	20
Freezer calendar	21
Defrosting	21
Freezer tray	22
Cool pack	22
Ice cube maker	23
Automatic defrost	24
Adjusting the interior fittings	25
Moving the shelves	25
Split shelf	25
Fruit and vegetable drawers on rollers	25
Moving the adjustable door shelves	26
Universal container	26
Moving the divider	26

Contents

Cleaning and Care	27
Cleaning the interior and accessories	28
Cleaning the ice cube tray	29
Ventilation slits	30
Door seal	30
Frequently asked questions	31
After sales service	36
Caring for the environment	38
Plumbing	39
Connecting the water supply	39
Electrical connection	41
Installation	42
Installation site	42
Ventilation	42
Ventilation grill	43
Before installation	43
Dimensions	45
Adjusting the door hinges	46
Installing the appliance	50
Custom door panels	50
Installing the appliance into a room divider	50
Mounting the cabinetry doors	55

IMPORTANT SAFETY INSTRUCTIONS

When using the appliance, follow basic safety precautions, including the following:

Read all instructions before installation and use to prevent accidents and machine damage.

This appliance is intended for residential use only. Use only as described in this Operating manual.

Only use this appliance for its intended purpose.

This appliance complies with current safety requirements. Improper use of the appliance can lead to personal injury and material damage.

Keep these operating instructions in a safe place and pass them on to any future user.

Electrical safety

- ▶ Before installation, make sure that the voltage and frequency listed on the data plate correspond with the household electrical supply. This data must correspond to prevent injury and machine damage. Consult a qualified electrician if in doubt.
- ▶ Before installation or use check the machine for any visible damage. A damaged machine is dangerous. Contact the Miele Service Department.
- ▶ Do not use an extension cord to connect this appliance to electricity. Extension cords do not guarantee the required safety of the appliance (e.g., danger of overheating).
- ▶ Be certain your appliance is properly installed and grounded by a qualified technician. To guarantee the electrical safety of this appliance, continuity must exist between the appliance and an effective grounding system. It is imperative that this basic safety requirement be met. If there is any doubt, have the electrical system of the house checked by a qualified electrician.
- ▶ Only connect power to the appliance when all installation and plumbing work is complete.

IMPORTANT SAFETY INSTRUCTIONS

Installation

This appliance is top-heavy and must be secured to prevent it from tipping forward.

- ▶ Before installation or service, disconnect the power supply to the work area by unplugging the unit, "tripping" the circuit breaker or removing the fuse.
- ▶ This appliance must be installed and connected in compliance with the installation instructions.
- ▶ Installation and repair work should be performed by a Miele authorized service technician. Work by unqualified persons could be dangerous and may void the warranty.
- ▶ Installation must comply with local plumbing regulations and state laws.
- ▶ Do not operate any appliance with a damaged cord or plug, or if the appliance has been damaged in any manner. Contact Miele's Technical Service Department.
- ▶ This appliance must not be used in a non-stationary location (e.g. on a ship).
- ▶ Do not install the fridge/freezer in a room with too low an ambient temperature, e.g., a garage, as this may lead to the appliance switching off for longer periods so that it cannot maintain the required temperature.
- ▶ In refrigerators with an automatic ice maker, avoid contact with the moving parts of the ejector mechanism. Do not place fingers or hands on the automatic ice making mechanism while the appliance is plugged in.
- ▶ The ice cube maker is not suitable for connection to a hot water supply.
- ▶ Do not use water that is microbiologically or chemically unsafe or of unknown quality without adequate disinfection or other treatment.
- ▶ Defective parts must only be exchanged with original Miele spare parts. Only then can the safety of the unit be guaranteed.

IMPORTANT SAFETY INSTRUCTIONS

Use

▶ This appliance is not designed for commercial use. It is intended for use in domestic households and in similar working and residential environments such as:

- shops, offices and similar work environments
- by customers in hotels, motels, Bed & Breakfasts or similar residential environments.

▶ This appliance is not intended for outdoor use.

▶ Persons who lack physical, sensory or mental abilities, or experience with the machine should not use it without supervision or instruction by a responsible person.

▶ To reduce the risk of injury, do not allow children to play in, on or near the appliance.

▶ After your appliance is in operation do not touch the cold surfaces in the machine, ice cubes or frozen food, particularly when hands are damp or wet. Skin may adhere to extremely cold surfaces.

▶ Do not refreeze frozen foods which have thawed partially or completely.

▶ Do not handle frozen food or ice with wet hands. Danger of injury.

▶ Do not store or use gasoline or other flammable vapors and liquids in the vicinity of this or any other appliance.

▶ Do not use sharp-edged objects to remove frost and ice, or separate frozen foods and remove ice trays. They will damage the evaporator, causing irreversible damage to the appliance.

▶ Do not use defrosting sprays or de-icers, as they might contain substances which could damage the plastic parts or which could cause a build-up of gases and pose a danger to health.

▶ Do not use any oils or grease on the door seal, as these will cause the seal to deteriorate and become porous with time.

▶ Do not block the ventilation gaps in the plinth or the top of the appliance housing unit, as this can impair the efficiency of the appliance, increase the electricity consumption and cause damage to the appliance.

▶ Never use a steam cleaner to clean the appliance. Pressurized steam could damage electrical components and cause a short circuit.

IMPORTANT SAFETY INSTRUCTIONS

Disposal of your old appliance

- ▶ Before disposing of an old appliance, first make the door latch or lock unusable.
- ▶ Take off the doors.
- ▶ Leave the shelves and drawers in place so that children may not easily climb inside.
- ▶ Be careful not to damage any part of the pipework while awaiting disposal by:
 - puncturing the refrigerant channels in the evaporator.
 - bending any pipework.
 - scratching the surface coating.Splashes of refrigerant can damage the eyes.

▶ Your old refrigerator may have a cooling system that used CFC's (chlorofluorocarbons). CFC's are believed to harm stratospheric ozone. If you intentionally release this CFC refrigerant, you can be subject to fines and imprisonment under provisions of environmental legislation. Make sure the CFC refrigerant is removed and disposed of by a qualified technician.

**SAVE THESE
INSTRUCTIONS**

Guide to the Fridge-Freezer combination

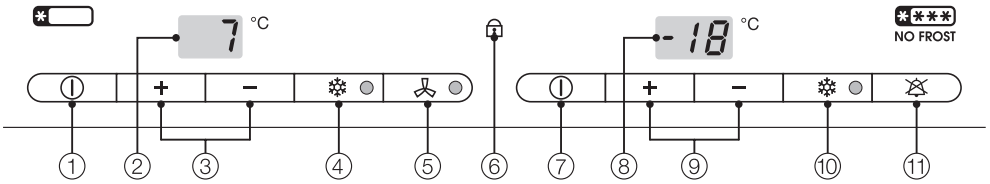

- ① On/Off button for the refrigerator section
- ② Temperature display for the refrigerator section
- ③ Temperature selection buttons for the refrigerator section (+ warmer; - colder)
- ④ Super button and indicator light for the refrigerator section
- ⑤ DynaCool button (dynamic cooling) and indicator light
- ⑥ Safety lock indicator light
- ⑦ Main switch to turn the whole appliance On/Off
- ⑧ Temperature display for the freezer section
- ⑨ Temperature selection buttons for the freezer section (+ warmer; - colder)
- ⑩ Super button and indicator light for the freezer section
- ⑪ Alarm-off button

Guide to the Fridge-Freezer combination

- ① DynaCool fan (Dynamic cooling)
- ② Hinged door shelf
- ③ Bottle rack
- ④ Adjustable door shelves
- ⑤ Interior lighting
- ⑥ Adjustable interior shelves
- ⑦ Condensate channel and drain hole
- ⑧ Universal container
- ⑨ Fruit and vegetable drawers
- ⑩ Divider
- ⑪ Bottle shelf
- ⑫ Ice cube drawer with automatic ice cube maker
- ⑬ Freezer drawers with calendar

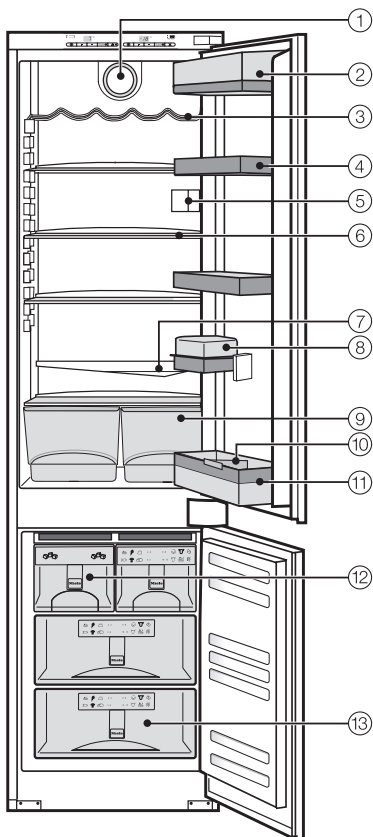

Before use

Before using for the first time

If the appliance was transported or laid horizontally for any reason, allow it to stand vertical for at least 8 hours before turning it on. Failure to do so will affect the functioning of the appliance.

Protective foil

The stainless steel trim, frames and panels have a layer of protective foil to prevent scratching during transportation.

- Carefully remove the protective foil.

Cleaning and care

- After removing the protective foil, treat stainless steel surfaces with the Miele stainless steel conditioning agent supplied with the appliance (available to re-order from www.mieleusa.com).

Important! Each time it is used, the Miele stainless steel conditioning agent forms a water and dirt repellent protective coating.

- Clean the inside of the appliance and the accessories with a mild solution of warm water and liquid dish soap, and then dry with a soft cloth.

Turning the appliance on

With the main switch you can turn the appliance on.

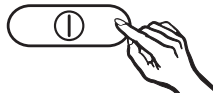

- Press the main switch on the right side of the control panel.

The temperature display for the refrigerator section lights up, and the interior lighting comes on when the door is opened.

Bars light up in the freezer section display until the selected temperature is reached.

The appliance begins cooling.

Allow the appliance to run for a few hours before placing food in it. This will enable it to sufficiently cool.

Cool pack

Place the cool pack in the top freezer drawer. The cool pack will be at maximum performance after it has been in the freezer for approx. 24 hours.

Turning the appliance off

- Press the main switch on the right side of the appliance until both temperature displays go out.

If the cooling system does not turn off the safety lock has been activated.

Turning the appliance on/Off

Turning the refrigerator section off

The refrigerator section can be turned off separately while the freezer section remains on, e.g. during vacation.

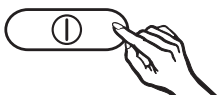

- Press the On/Off button on the left side of the control panel until the temperature display for the refrigerator section goes out.

Turning the refrigerator section on

- Press the On/Off switch on the left side of the control panel until temperature display for the refrigerator section turns on.

The refrigerator section will begin to cool and the interior lighting will turn on when the door is opened.

Safety lock

The safety lock can be activated to prevent the appliance from being turned off accidentally.

Activating/Deactivating the safety lock



- Press the Super button for the freezer for approx. 5 seconds.

The Super indicator light flashes, and ϵ flashes in the temperature display.



- Press the Super button for the freezer again.

ϵ will appear in the display.

- Using the temperature selector buttons you can now choose between $\epsilon 0$ and $\epsilon 1$:
 0 : safety lock deactivated,
 1 : safety lock activated.

- Press the Super button for the freezer to save the setting.

The safety lock indicator lights up in the display  when it is activated.

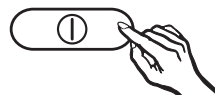

- Press the main switch on the right side on the control panel to exit the settings mode.

If a button is not pressed within 2 minutes the electronics will return to normal operation.

Before use

Preparing your Appliance for an Extended Vacation

If the appliance is not going to be used for an extended time (for example, during a vacation) some precautions should be taken.

- Shut off the water supply line, (several hours before switching off the appliance)
- Take all food out of the appliance
- Turn the appliance off at the main switch, unplug the appliance and disconnect the fuse.
- Discard any ice cubes
- Clean the interior
- Leave the doors open to prevent odors

If you elect to turn off the water to your home for an extended period of time, please note that this may not be enough to reduce the risk of a leak.

To be completely safe, you must turn off the water supply to each individual appliance. This means under the sink for a dishwasher, at the laundry bib for your washer, etc.

Setting the temperature

Temperature range

The temperature can be selected within the following ranges:

- Refrigerator:
39°F (4° C) to 48°F (9° C).

A temperature of 39°F (4° C) is recommended in the refrigerator section.

- Freezer:
3°F (-16° C) to -15 (-26° C).

To freeze fresh food and store frozen food for an extended period of time, a temperature of 0°F (-18°C) is suggested.

Partially or completely thawed food must never be refrozen.

The room temperature and the installation location can affect the time it takes for the appliance to get to the desired temperature. If the room temperature is too high, it may not be possible for the appliance to reach the lowest temperature.

Setting the temperature in the refrigerator and freezer sections

The temperatures for the refrigerator and freezer sections can be set independently using the temperature selection buttons.



- + button: increases the temperature
- button: decreases the temperature

The temperature being set will flash in the display.

When pressing the buttons the following information appears in the display:

- When first pressed: The **last selected temperature** flashes.
- Each subsequent press of the button adjusts the temperature in increments of 1 °F (1°C).
- Holding down the button will move through the temperature range quickly.

Approx. 5 seconds after releasing the button the **current, average** temperature in the refrigerator or freezer section is automatically shown.

If the temperature is adjusted, wait approx. 6 hours (or 24 hours for a fully loaded appliance) for the temperature display to show an accurate reading. If after this time the temperature is still too high or low, try adjusting it again.

Setting the temperature

Temperature displays

During normal operation, the temperature display shows the temperature in the middle of the refrigerator section and the temperature in the warmest part of the freezer section.

If the temperatures in the appliance are not in the possible temperature display range, dashes will flash in the temperature displays.

The **temperature displays flash** if:

- a different temperature is being set,
- the temperature in the appliance has risen by several degrees, indicating that the appliance is warming up too much.

This short-term loss of cooling is not a cause for concern in the following cases:

- when the door has been left open for a longer period, for example to take out or put in a large amount of food,
- when fresh food is being frozen.

However, if the temperature remains above 0°F (-18° C) for a longer period of time, you will need to check to make sure that any frozen food has not started to thaw. Any food that has started to thaw should be used as soon as possible.

Setting the temperature

Temperature display brightness

The brightness of the temperature display is factory-set to the lowest setting.

However when the door is opened, a setting is changed or an alarm is triggered, the temperature display will appear very bright.



- Hold down the Super button for the freezer for approx. 5 seconds.

The Super indicator flashes and **h** flashes in the temperature display.

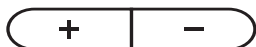

- Press either of the temperature selection buttons until **h** appears in the display.
- Press the Super button for the freezer again.

h appears in the display.

- Using the temperature selector buttons, you can now choose a brightness level from **1** to **5**:
1 dimmest setting
5 brightest setting.
- To save the setting, press the Super button for the freezer.

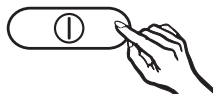

- Press the main switch on the right side on the control panel to exit the settings mode.

If a button is not pressed within 2 minutes the electronics will return to normal operation.

Alarm

The appliance is equipped with an alarm system, to ensure that the temperature does not rise unnoticed.

The alarm system is always operational, it does not need to be turned on.

If the temperature becomes too warm, the alarm sounds and the temperature display for the freezer section flashes. The temperature set will determine when the alarm is triggered.

The alarm will sound and the display will flash if:

- too much warm air flows into the appliance, for example when food is being loaded, re-arranged, or taken out.
- large amounts of food are being frozen at once.

Door alarm

If one of the appliance doors is left open for more than 60 seconds, the alarm signal will sound.

Turning the alarm off

Once the set temperature is reached in the freezer, the alarm signal turns off and the temperature display stops flashing.



- **To turn the alarm off early**, press the alarm off button.

The alarm signal turns off. The temperature display will continue to flash until the set temperature has been reached. The display then stops flashing and lights steadily. The alarm system is automatically reactivated.

Using the Super and DynaCool functions

Super function

The Super function is used to rapidly reduce the temperature in the refrigerator and freezer sections to their lowest settings (depending on the room temperature).

When used with the **refrigerator** the Super function is ideal for the rapid cooling of drinks and refrigerating large quantities of food.

When used with the **freezer** the Super function is ideal for freezing large quantities of unfrozen food. The function should be switched on approx. 6 hours before the fresh food is placed in the freezer. If the max. freezing capacity is used allow 24 hours. This helps food to freeze quickly and retain its nutrients, vitamins, flavor and appearance.

It is not necessary to use the Super function in the freezer if you are loading frozen food or if you are loading less than 4.4 lbs (2 kg) of food.

Turning on the Super function for the refrigerator/freezer

- Press the Super button for the refrigerator or freezer as desired, the indicator light will turn on.

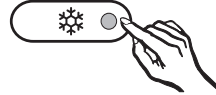

The appliance will now work at full power to lower the temperature in the refrigerator/freezer section.

Turning off the Super function for the refrigerator/freezer

The Super function automatically turns off after:

Refrigerator: approx. 6 hours

Freezer: approx. 30 - 60 hours
(depending on the amount of food frozen).

The indicator light will go out, and the appliance will run at normal power.

The Super function can be turned off early, once a constant temperature of 0°F (-18° C) or colder has been reached in the freezer section, or once the food and/or drinks are sufficiently chilled in the refrigerator.



- **To turn the function off early**, press the Super button for the refrigerator or freezer as desired, the indicator light will go out.

The appliance will now run at normal power.

Using the Super and DynaCool functions

DynaCool

If the dynamic cooling function (DynaCool) is not switched on, the natural circulation of air throughout the appliance can create different temperature zones in the refrigerator section, with the colder, heavier air sinking to the lowest section. See "Using the refrigerator efficiently".

If you are placing a large amount of food in the refrigerator at one time, the DynaCool function is recommended. This will help to distribute the temperature evenly throughout the cavity so all food will be chilled to about the same temperature. The temperature can be set as usual, with the temperature selection buttons.

DynaCool should also be selected if:

- the room temperature is high (above approx. 86°F (30 °C), and
- the humidity is high.

Turning on DynaCool

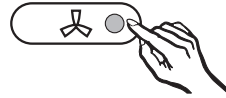

- Press the DynaCool button, the indicator light will turn on.

Turning off DynaCool

- Press the button for DynaCool button, the indicator light will go out.

When the door is open, the fan automatically turns off.

Using the refrigerator efficiently

Different storage zones

Due to the natural circulation of air in the appliance, there are different temperature zones in the refrigerator. Cold, heavy air sinks to the lowest section of the appliance. Make use of these different zones when placing food in the appliance.

This appliance uses a dynamic cooling feature (DynaCool) to establish a constant temperature during cooling. As a result, the differences between temperature zones are less pronounced.

Leave some space between items so that air can circulate freely around them. Do not cover the fan in the rear wall - this is important for cooling performance!

Warmest area

The warmest area is in the top section of the door. Use this area to store items such as butter and cheese.

Coldest area

The coldest area in the refrigerator section is directly above the fruit and vegetable drawers.

Use these cold areas in the refrigerator for all highly perishable foods, such as:

- fish, meat, poultry,
- deli meats, store-bought meals,
- dishes or baked goods containing eggs or cream,
- fresh bread dough, pastry dough, cake batters,
- dairy products.

Never store explosive materials in the appliance, or products with flammable propellants (e.g. spray cans,). Danger of explosion!

If storing high-proof alcohol, make sure it is tightly closed and stored upright.

Do not store cooking oil in the refrigerator door. Traces of oil can cause stress cracks to occur in the plastic components in the door.

Do not allow food to touch the rear wall of the appliance, it may freeze to the wall.

Using the freezer efficiently

Maximum freezing capacity

To ensure that food is frozen thoroughly, the maximum freezing capacity should not be exceeded.

See the data plate:

"Freezing capacity.....lb/kg/24 hrs".

Freezing food

Fresh food should be frozen as quickly as possible. This helps maintain the nutritional value, vitamin content, appearance and taste of the food.

Never refreeze partially or fully defrosted food. Consume defrosted food as soon as possible, it will lose its nutritional value and spoil if left for too long. Do not refreeze defrosted food unless it has been cooked.

Before placing food in the freezer

- When you are planning to freeze large amounts of food (more than 4 ½ lbs [2 kg]), turn on the Super function for the freezer ahead of time (see "Super").

This will provide the food already in the freezer with a protective boost of cold air.

Placing food in the freezer

Food to be frozen can be placed anywhere in the freezer section.

Large quantities of food should be placed directly on the glass plates to freeze the food quickly. To do this, remove the two top freezer drawers. When taking these drawers out be sure not to block the ventilation slits in the back wall of the appliance. They are important for trouble-free operation of the appliance.

The lowest freezer drawer should not be removed.

Each drawer and each glass plate can hold a maximum of 55 lbs (25 kg).

- Place the food flat in the bottom of the freezer drawers or on the glass plates, so that it will freeze through to the core as quickly as possible.
- When placing items in the freezer, make sure the packaging and containers are dry, to keep them from sticking together when frozen.

When freezing, make sure that already frozen food does not come into contact with fresh food being frozen, this could cause the frozen food to defrost.

Using the freezer efficiently

Freezing large items

If you would like to freeze large items e.g. turkey or ham, the glass plates between the drawers can be removed.

- Remove the top full-width freezer drawer, and carefully lift and slide out the glass plates.

Freezer calendar

The calendar on the freezer drawers indicates the suggested length of time (in months) which various foods should be stored.

If the storage time given on the packaging differs, follow the advice on the packaging.

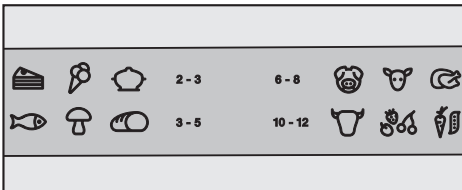

A grid of icons representing different food categories and their recommended storage durations in months. The icons are arranged in two rows. The first row shows a cake, ice cream cone, and stew/soup bowl, with '2-3' below them. The second row shows a fish, mushroom, and bread, with '3-5' below them. The third row shows a pig, veal, and poultry, with '6-8' above them. The fourth row shows beef, fruits, and vegetables, with '10-12' above them.

Type of food	Length of time (months)
Cakes, ice cream, stews/soups	2 - 3
Fish, mushrooms, bread	3 - 5
Pork, veal, poultry	6 - 8
Beef, fruits, vegetables	10 - 12

Defrosting

Frozen food can be defrosted in different ways:

- in a microwave oven,
- at room temperature,
- in the refrigerator (the cold given off by the frozen food helps to keep the other food cold),
- in a steam oven.

Thin pieces of meat and fish can be placed directly in a hot pan without defrosting.

Poultry It is especially important to observe proper hygiene when defrosting poultry. Never save the liquid from defrosted poultry. Drain it away and promptly wash the container, the sink and your hands. Danger of salmonella poisoning.

Fruit should be defrosted at room temperature in its packaging, or in a covered bowl.

Most vegetables can be cooked while still frozen. Simply place directly into boiling water or hot oil.

Using the freezer efficiently

Cooling drinks quickly

To cool drinks quickly, turn on the Super function for the freezer. See "Super" for more information.

Do not leave bottles in the freezer for more than **1 hour**, closed containers could burst.

Freezer tray

The freezer tray can be used to freeze small items such as berries, herbs and vegetables. They are frozen individually and therefore maintain their shape when defrosted.

- Load the items loosely onto the freezer tray.

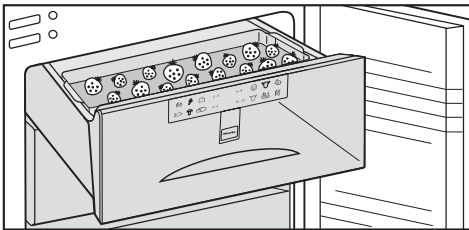

- Hang the tray on one of the upper freezer drawers.

Allow 10 - 12 hours for the items to freeze thoroughly. Then transfer them to a suitable container or bag.

Cool pack

The cool pack prevents the temperature in the freezer from rising too quickly in the event of a power failure.

Place the cool pack in the top freezer drawer, directly on top of the food. The pack will be at its most effective after approx. 24 hours.

If there is a power failure the cool pack will help keep food cold as long as possible.

When placing fresh food in the freezer, use the cool pack to separate the fresh food from the already frozen food. This will prevent the frozen food from beginning to thaw.

For the automatic ice cube maker to operate, it must be connected to the household water supply. See "Plumbing".

Turning on

- Turn the appliance on.
- Open the top left drawer of the freezer section.

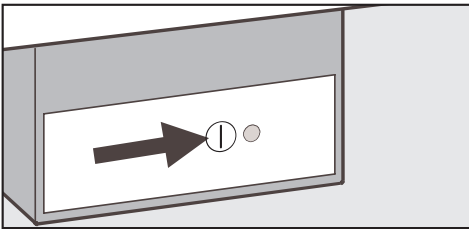

- Press the On/Off button on the ice cube maker. The indicator light will come on.
- Close the drawer.

Ice cubes will not be produced unless the drawer is completely closed.

After the appliance is turned on for the very first time, it can take up to 24 hours for the first ice cubes to drop out of the ice cube maker and collect in the drawer.

Thereafter, when the ice cube maker is turned off then on again it will take a maximum of 6 hours for ice cubes to be produced.

Do not use the ice cubes from the first three ice productions. This will ensure that the water supply lines are flushed.

This applies for the very first use, and whenever the appliance has been out of service for an extended period of time.

Making a large amount of ice cubes

The amount of ice cubes produced depends on the temperature in the freezer section. The lower the temperature, the more ice cubes will be produced in a given period of time.

The ice cube production is interrupted automatically as soon as the ice cube drawer is full.

- To produce a larger amount of ice cubes exchange the ice cube drawer with the drawer on the right.

As soon as the drawer is closed the ice production will continue.

Turning off the ice cube maker

- Press the On/Off button on the ice cube maker until the indicator light goes out.

If the ice cube maker is turned off, the ice cube drawer can be used to store food.

Automatic defrost

Refrigerator section

The refrigerator defrosts automatically.

During normal operation, condensate and frost can form on the rear wall of the refrigerator and drawers.

You do not need to remove this build-up, it will defrost and evaporate automatically with the heat generated by the appliance.

The condensate is drained away via a channel and drain hole into an evaporation system at the back of the appliance.

Be sure that the condensate channel and drain hole are kept clean and are unblocked so that condensate can flow away easily.

Freezer section

The freezer defrosts automatically.

The moisture generated in the appliance collects on the condenser and is automatically defrosted and dissipated by the condenser from time to time.

This automatic defrosting system enables the freezer to remain permanently ice-free, however the food stored remains frozen.

Adjusting the interior fittings

Moving the shelves

The shelves can be adjusted according to the height of the food:

- Lift the shelf, pull it forwards slightly, until the notch at the side is in line with the shelf support. It can now be moved up or down as desired.

The raised edge at the back of the shelf must face upwards to prevent food from touching the back of the appliance.

Stops prevent the shelves from unintentionally being pulled out too far.

Split shelf

To accommodate tall items such as tall bottles or containers, one of the shelves is divided. The front section can be gently pushed under the rear section:

- Push the rear half of the glass shelf up slightly from below.
- At the same time, pull the front half of the glass shelf forwards slightly and then push it carefully under the rear half.

To move the split shelf:

- Remove both halves of the glass.

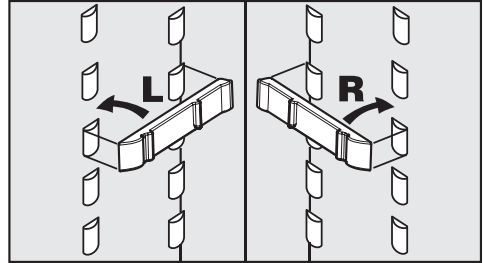

- Fit the brackets onto the support on the left and right sides at the desired height.
- Slide in the glass shelves one after the other. The glass shelf with the raised edge should be placed at the back.

Fruit and vegetable drawers on rollers

(depending on model)

The fruit and vegetable drawers are mounted on rollers and can be pulled out for loading, unloading and cleaning. The roller inserts can also be removed for cleaning.

Adjusting the interior fittings

Moving the adjustable door shelves

- Lift the shelf up and out of the stainless steel frame.
- Push the stainless steel frame up and remove, by pulling it forward.
- Replace the frame at the desired height. Ensure that it is securely pushed back into position.

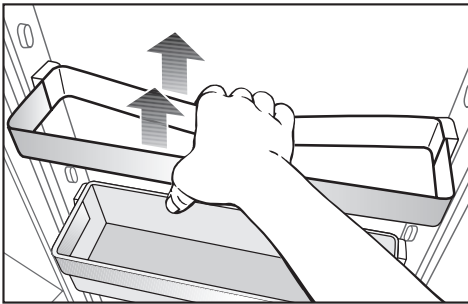

- Some stainless steel frames are easier to remove and replace if you put your hand behind the back bar of the frame and lift it upwards.
- Place the shelf into the frame.

The shelves can be removed for loading, unloading, cleaning or serving and then replaced.

Universal container

Food can be stored as well as served in the universal container.

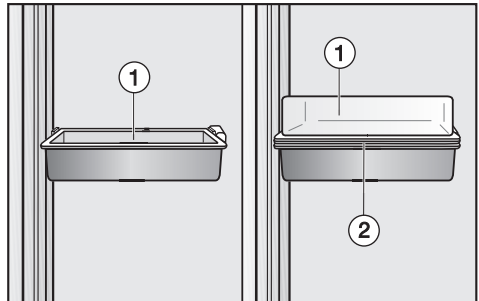

The universal container consists of a deep tray ① and a shallow tray ②. Both trays can be fit into the stainless steel frame.

- To use the universal container to serve food, place the shallow tray ② in the stainless steel frame and use the deep container as a lid ①.

Moving the divider

(depending on model)

The divider can be moved to the left or right to ensure that bottles are held securely in position when the door is opened and closed.

The divider can be removed completely (e.g. for cleaning):

- Lift the front edge of the divider up and out.

To reduce the risk of electrical shock, disconnect the appliance from the power supply by shutting off the power main, tripping the circuit breaker or unplugging the power cord before maintenance.

Treat stainless steel surfaces with Miele stainless steel conditioning agent (available from Miele or www.mieleusa.com).

Unlike stainless steel cleaning agents, the conditioning agent does not contain any abrasive substances and will gently remove soiling. Each time it is used, it forms a water and dirt repellent protective coating.

Do not let water get into the electronic unit or the light.

Do not let water get into the drainage channel and drain hole when cleaning.

Do not use a steam cleaner to clean the appliance. Steam could reach the electrical components and cause a short circuit.

The data plate located inside the appliance must not be removed. It contains information which is required in the event of a service call.

To better maintain your appliance avoid the following:

- cleaners containing soda, ammonia, thinners, or chlorides
- cleaners containing descaling agents or lime removers,
- abrasive cleaners,
- stainless steel cleaners,
- dishwasher soap (powder),
- caustic (oven) cleaners,
- scouring pads, steel wool, hard brushes,
- metal scrapers,
- steam cleaning products.

Glass cleaners may be used to clean the exterior. However **do not** allow them to sit or "puddle", this can cause damage to the surface.

Remove the cleaner promptly.

Cleaning and Care

Before cleaning

- Turn the appliance off.
- Turn the appliance off at the main switch, unplug the appliance and disconnect the fuse.
- Take any food out of the appliance and store it in a cool place.
- Take out any removable parts, e.g. shelves, for cleaning.
- The bottle shelf and condiment tray in the door can be removed from their stainless steel frames for cleaning.

To remove the stainless steel trim from the lid of the butter and cheese compartment (in the top of the door), proceed as follows:

- Take the butter and cheese compartment out of the refrigerator section.
- Open the lid of the compartment.

The stainless steel trim is a tight fit across the plastic lid and will require sufficient force to detach it.

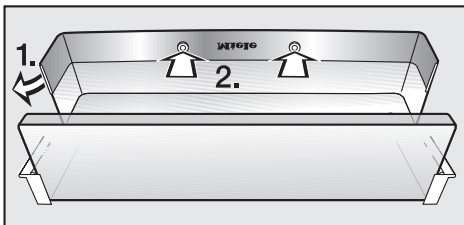

- Detach the stainless steel trim from the edge of the lid (1.) at one side and remove.
- Press the white plastic stoppers out of notches (2.).

- After cleaning, refit the stainless steel trim onto the lid in the reverse order.

Cleaning the interior and accessories

- Clean the appliance at least once a month using a mild solution of warm water and liquid dish soap.

The following are dishwasher safe:

- the butter dish, egg trays, ice cube tray (depending on model)
- the bottle and condiment shelves in the door (removed from their stainless steel frames)
- the butter and cheese compartment (with the stainless steel trim removed)

The stainless steel frames and the stainless steel trim on the butter and cheese compartment in the door are not suitable for cleaning in a dishwasher.

The temperature of the dishwasher program must not exceed 130°F (55 °C). Contact with foods, such as carrots, tomatoes or ketchup can cause plastic items to discolor. However, this discoloration will not affect the stability of plastic items.

- Clean the interior shelves and drawers by hand. These are not suitable for cleaning in a dishwasher.

- Clean the condensate channel and drain hole frequently, so that condensate can drain away unhindered. Use a straw or similar to clear the drain if necessary.
- After cleaning, wipe the interior and accessories with a damp cloth and dry with a soft cloth. Leave the door open to air the appliance for a short while.
- Use the Miele stainless steel conditioning agent to remove any soiling from stainless steel surfaces.
- It is important to treat the stainless steel trim, frames and panels with Miele stainless steel conditioning agent each time they are cleaned. This will protect the surface and help prevent resoiling.

Cleaning the ice cube tray

The ice cubes are formed in a tray before they are dropped into the drawer.

The tray should be cleaned regularly to remove any stale ice or water.

- Connect the appliance to the electrical supply.
- Press the On/Off button for the ice cube maker, the indicator light will turn on.
- Empty the ice cube drawer.
- Press the On/Off button for the ice cube maker for approx. 10 seconds (after approx. 1 second the ice maker will turn off and the indicator light will go out).

The indicator light will flash.

- Push the ice cube drawer in as far as it will go within the next 60 seconds.

The ice cube tray will then rotate into an angled position for easier cleaning.

Wait until the ice cube tray has completed this rotation before continuing.

- Remove the ice cube drawer.
- Clean the ice cube drawer and tray with a mild solution of warm water and liquid dish soap.
- Press the On/Off button on the ice cube maker.

The ice cube tray rotates back into its original position.

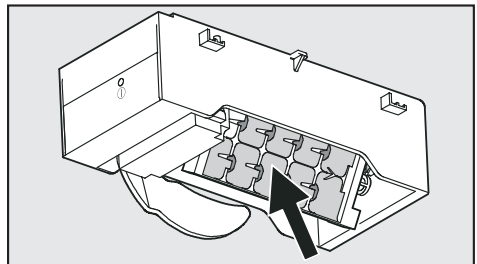

- Replace the ice cube drawer and close.

The ice cube maker will begin producing ice cubes again after a maximum of 6 hours.

If the ice cube maker has not been used for an extended period of time, it is important to clean the ice cube tray before using it again.

Cleaning and Care

Ventilation slits

- Check the ventilation slits regularly. Remove any dirt/dust with a vacuum cleaner or brush. Clean as needed.

Door seal

Do not use oil or grease on the door seals. This may cause the seals to deteriorate and become porous over time.

- Clean the door seals with warm water and dry thoroughly

After cleaning

- Return all shelves, drawers and accessories.
- Place food back in the refrigerator section, close the appliance door, insert the plug in the power outlet and turn the appliance on.
- Turn on the Super function for the freezer to cook the freezer section quickly. The indicator light will come on.
- Once the freezer has reached a constant of 0°F (-18 °C) or colder, place the food back in the drawers and replace them in the freezer section and turn off the Super function.

Frequently asked questions

With the aid of the following guide minor problems can be corrected without a service call.

Repairs should only be carried out by a qualified and trained person in strict accordance with local and national safety regulations. Unauthorized repairs could cause personal injury or machine damage and may void the warranty.

The refrigerator or freezer section does not get cold.

Possible fault	Solution
The machine is not turned on.	Check whether the appliance is switched on at the main switch. The appropriate temperature display must be lit up.
The machine is not plugged in.	Check that the plug is correctly inserted in the power outlet.
Check that the fuse has not tripped.	Reset the circuit breaker. If the breaker trips again the appliance or the outlet may be defective. Contact Miele or a qualified electrician.

The temperature in the refrigerator or freezer section is too low.

Select a warmer temperature.	See "Setting the temperature".
The Super function is still on.	The Super function automatically turns off after: Refrigerator: approx. 6 hours Freezer: approx. 30 - 60 hours (depending on the amount of food frozen).
The door is not closed.	Check that the doors are closed properly.
A large amount of food is being frozen at the same time.	This makes the compressor run longer, causing the temperature in the freezer section to fall automatically.

The freezer section is too warm.

The room temperature is lower than the ambient temperature for which the appliance is designed.	Raise the temperature of the room. Operating the appliance in a room that is too cold will cause the cooling system to turn off for too long, causing the freezer section to become too warm.
---	--

Frequently asked questions

The door to the freezer section will not open.	
Possible fault	Solution
This is not a fault. The suction caused by opening and closing the door too many times in succession prevents it from opening.	Wait a few minutes, then try again. It should now open without force.
The compressor kicks on very frequently and for too long.	
The ventilation slits are covered or dusty.	Clean with a vacuum or brush.
The doors have been opened too frequently, or a large amount of fresh food has been put in at once for freezing.	Once the fridge/freezer gets down to the set temperature the compressor will turn off.
The door is not closed.	Check that the doors have been closed properly.
The compressor runs continuously.	
To save energy, the compressor runs at a lower speed, but for longer, when less cooling is required. This is not a fault.	
The appliance will not turn off.	
The safety lock has been activated. (See "Safety Lock".)	
The interior lighting of the refrigerator section is not working.	
<p>Do not remove the cover. Should the cover be damaged or need to be removed due to damage, exercise caution. There are lasers in the lighting (laser beam class 1M) which you should avoid looking at directly. Do not use optical instruments (magnifying glass or similar) to look at the lighting either.</p>	
The refrigerator door has been left open for too long.	The lighting turns itself off automatically after approx. 15 minutes.
If the lighting does not come on when the door is opened briefly, but the temperature display is working, then the lighting is defective.	Contact Miele Technical Service. The LED lighting should only be repaired/replaced by a Miele service technician. Danger of injury or damage.

Frequently asked questions

The floor of the refrigerator is wet.	
The drain hole is blocked.	Clean the condensate channel and drain hole.
The alarm sounds.	
Possible fault	Solution
The appliance door(s) have been open for longer than 60 seconds.	Close the door(s).
The alarm sounds and the temperature display for the freezer section flashes.	
The freezer door has been opened too frequently.	This has caused the temperature in the freezer to rise above the set temperature. Once the temperature has dropped to the correct level again the alarm will stop and the display will stop flashing.
A large amount of food is being frozen at the same time.	
Bars light up or flash in the temperature displays.	
Only temperatures within the range of the appliance can be shown in the display. Check the display again about 6 hours after turning it on.	
A fault code of "F0" to "F5" appears in one of the temperature displays.	
A fault has occurred. Contact Miele Technical Service.	
The Super indicator light for the freezer section and the temperature display are both flashing.	
A fault has occurred. Contact Miele Technical Service.	
The Super indicator light for the freezer section is not on, but the refrigerator is running.	
The indicator light is faulty.	Contact Miele Technical Service.

Frequently asked questions

"nA" appears in the temperature display for the freezer section.

The temperature in the freezer section has risen too high at some point during the last few days because of a power failure.

- Press the alarm off button while "nA" is lit in the display.

The display will show the warmest temperature reached in the freezer during the power failure for about 1 minute. The display will then revert to the current temperature in the freezer section.

After the power failure the appliance will continue running at the last temperature set, there is no need to re-set.

The ice cube maker will not turn on.

Possible fault

Solution

The appliance is not plugged in.

Check that the appliance is connected to the power supply.

The ice cube maker is not producing any ice cubes.

When the appliance is turned on for the very first time, it can take up to 24 hours for the first ice cubes to drop out of the ice cube maker and collect in the container.

The water supply line was not primed (purged of air) before the appliance was used for the first time.

Contact Miele Technical Service.

The appliance is not turned on.

Check that the appliance is switched on, using the main switch on the right side.

The ice cube maker is not turned on.

See "Ice cube maker - Turning on".

The water supply is not open.

See "Plumbing".

The indicator light on the ice cube maker is flashing.

A fault has occurred. Contact Miele Technical Service.

Frequently asked questions

The appliance is making noises.		
Issue	Possible fault	Solution
Brrrrr...	Humming noise made by the compressor. This noise can get louder for brief periods when the motor is switching on.	<p>These noises are not a fault.</p> <p>The noise of the compressor and the coolant circulating in the system is unavoidable.</p>
Blubb, blubb...	A gurgling noise can be heard when coolant is circulating through the pipes.	
Click...	Clicking sounds are made when the thermostat switches the compressor on and off.	
Sssrrrrr...	On multi-zone and frost-free appliances you can sometimes just hear the movement of air circulating inside the appliance.	
Creaking	Creaking sounds can be heard when material inside the appliance expands.	
Rattling, vibrating	The appliance is uneven.	Realign the appliance using a level, by raising or lowering the screw feet underneath the appliance.
	The appliance is touching another appliance or piece of furniture.	Move it away.
	Drawers, baskets or shelves are unstable or sticking.	Check all removable items and refit them correctly.
	Bottles or containers are unstable or knocking against each other.	Separate them.
	The transport cable clips are hanging loose at the back of the appliance.	Remove the clips.

After sales service

In the event of a fault which you cannot easily fix yourself, please contact the Miele Technical Service Department at the address on the back of this booklet.

When contacting the Technical Service department, please quote the model and serial number of your appliance given on the data plate inside the appliance.

MieleCare

(USA only)

MieleCare, our Extended Service Contract program; gives you the assurance of knowing that your appliance investment is covered by 5 years of worry-free ownership.

MieleCare is the only Extended Service Contract in the industry that guarantees repairs by a Miele Authorized Service Provider using genuine Miele parts. Only genuine Miele parts installed by factory-trained professionals can guarantee the safety, reliability and longevity of your Miele appliance.

Please note that unless expressly approved in writing by the Miele Service department, Extended Service Contracts offered by other providers for Miele products will not be recognized by Miele. Our goal is to prevent unauthorized (and untrained) service personnel from working on your Miele products, possibly doing further damage to them, you and/or your home.

To learn more about **MieleCare** Extended Service Contracts, please contact your appliance dealer or visit us online at:

<http://mieleusa.com/mielecare>



Installation instructions

Information is subject to change. Please refer to our website to obtain the most current product specification, technical & warranty information.

To prevent accidents
and machine damage
read these instructions

before
installation or use.

Caring for the environment

Disposal of packing materials

The cardboard box and packing materials are biodegradable and recyclable. Please recycle.

Ensure that any plastic wrappings, bags, etc., are disposed of safely and kept out of the reach of babies and young children. Danger of suffocation!

Disposal of an old appliance

Old appliances contain materials that can be recycled. Please contact your local recycling center about the possibility of recycling these materials.

Before discarding an old appliance, disconnect it from the electrical supply and cut off the power cord to prevent it from becoming a hazard.

All plumbing work should be carried out by a suitably qualified and competent person, in accordance with all applicable local and national regulations.

The water quality must conform to country requirements for drinking water.

- The appliance is only suitable for connection to the cold water supply.
- Water pressure on-site:
Minimum: 21.76 psi
Maximum: 87.02 psi, if higher, install a pressure reduction valve.
- Use only the supplied stainless-steel hose (length: 78 3/4" [2 m]).
Do not re-use older hoses.
- A separate shut-off valve must be installed, so that the water supply can be interrupted as needed. If one is not present, have a water valve installed by a licensed plumber. It must be easily accessible after the appliance has been built-in.
- Be sure not to kink or damage the hose when pushing the appliance into the installation niche.

Connecting the water supply

Before any installation or maintenance work is performed be sure the appliance is disconnected from the electrical supply.

Connection to the water supply should include a shut-off valve with a 3/4" thread.

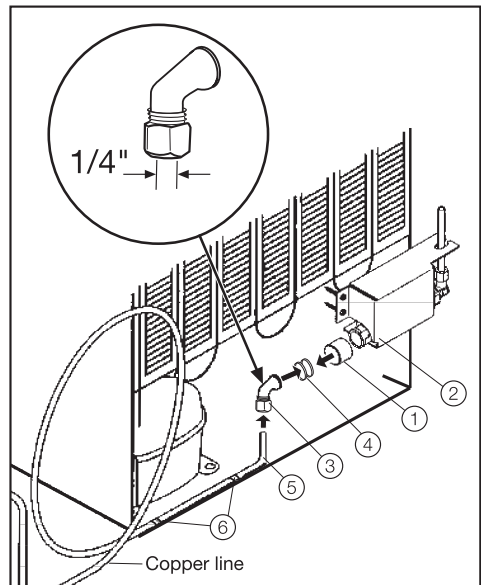

- Remove the cover cap ① from the solenoid valve ②.
- Install the compression fitting ③ with the sealing ring ④ on the solenoid valve ②.
- Attach the copper line ⑤ to the compression fitting ③.
- Secure the copper line to the appliance using cable clips ⑥.

Plumbing

- Open the water supply slowly and check the water system for leaks.
- The appliance can now be connected to the electrical supply (see "Electrical connection").

Before using the appliance for the first time the water pipe should be purged of air by a qualified person.

- Slide the appliance into the installation niche.

Be sure not to kink the hose, otherwise there is the risk of leaks and water damage.

After a maximum of 24 hours the first ice cubes will drop out of the ice cube maker and collect in the drawer.

 Avoid the risk of electrical shock

- Plug into a grounded 3-prong outlet.
- Do not move the ground plug.
- Do not use an adapter.
- Do not use an extension cord.

Failure to follow these instructions can result in death, fire, or electrical shock.

Improper connection of the equipment grounding conductor may result in electric shock. If you are in any doubt as to whether the appliance has been properly grounded, have the appliance checked by a qualified electrician or service technician.

Installation, repairs and other work by unqualified persons could be dangerous.

Before installing the appliance, verify that the voltage, load and circuit rating information found on the data plate match the household electrical supply.

The appliance is supplied with a UL-listed, 3-wire power cord and NEMA 5-15 P plug ready for connection to a 120 V, 60 Hz supply. The fuse rating is 15 amps.

The appliance requires a 3-wire receptacle.

The receptacle must be installed by a licensed electrician only.

In the case of side-by-side installations, a separate outlet must be used for each appliance. Ideally, the power outlet should be next to the appliance and easily accessible. Do not connect the appliance to the power supply by an extension cord. Extension cords do not guarantee the required safety of the appliance (danger of overheating).

If any changes are needed to the household wiring or power supply, this work must be performed by a qualified electrician.

If there are any questions regarding the electrical connection of this appliance to the power supply, please consult a licensed electrician or call the Miele Technical Service.

 1-800-999-1360

 1-800-565-6435

Installation

Have the appliance installed by a qualified technician, according to the enclosed installation instructions.

WARNING

This appliance is top-heavy and must be secured to prevent it from tipping forward.

Installation site

The appliance should be installed in a dry, well-ventilated room.

Do not install the appliance:

- outdoors
- in an environment with dripping water
- in rooms that are at risk of frost.

The installation location should not be exposed to direct sunlight, or near a heat source, such as an oven, radiator, etc.

The ambient temperature should not drop below 50°F (10°C) or rise above 110°F (43°C), otherwise malfunctions may occur.

If installation next to a heat source is unavoidable, use a suitable insulating plate or observe the following minimum distances from the heat source:

- 1 1/4" (3 cm) from an electric cooktop or oven.
- 12" (30 cm) from a gas cooktop or oven.

Ventilation

The air at the rear wall of the appliance gets warm. Therefore sufficient space must be provided around the appliance for ventilation.

Air is taken in through the plinth of the furniture housing unit.

A ventilation gap of at least 1 1/2" (38 mm) depth must be allowed for behind the appliance for air to circulate. The cross-sectional area of the ventilation gaps and also the cross-sectional area beneath the ceiling needs to be at least 78 3/4" ² (200 cm²) throughout to ensure that warm air can escape without obstruction.

The air intake and outlet must not be blocked or covered in any way. They also need to be dusted/cleaned on a regular basis.

Ventilation grill

During construction the ventilation grill can be built-in.

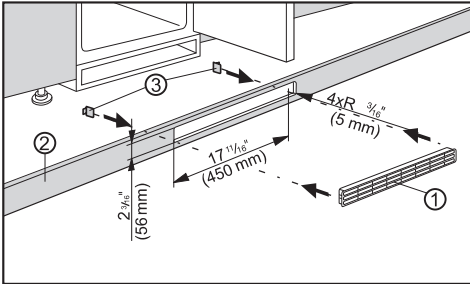

- Cut an opening into the plinth ②, as shown in the illustration above.
- Place the ventilation grill ① into the cut-out.
- Slide the clips ③, from the back, into the ventilation grill until the hooks connect with the plinth.
- Install the plinth with the inserted ventilation grill.

Before installation

- Remove the cover strip, the sealing strip and other accessories from the inside and from the exterior rear wall of the appliance.

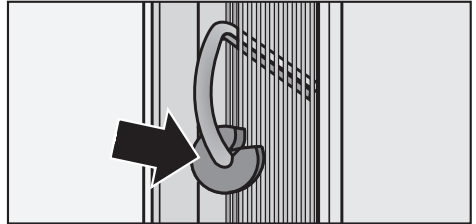

- **Do not** remove the spacers from the rear wall of the appliance. They ensure that there is enough space between the rear wall of the appliance and the wall.
- Remove the cable clips from the rear of the appliance.

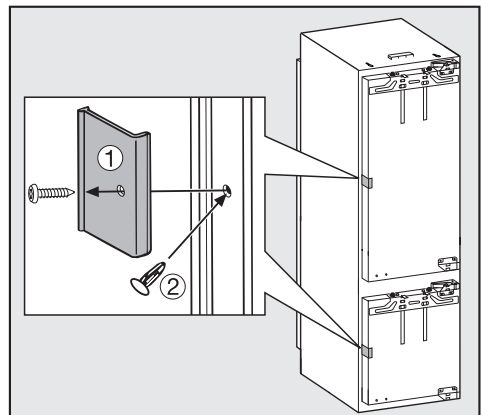

- Remove the red transport fixing ①, and use the supplied plug ② to close the empty hole.
- Check that all the parts on the rear the appliance can move freely. Bend any parts carefully if needed.

Installation

Did the old appliance have a different hinge system?

Even if your old appliance had a different hinge system you can still use a custom door panel.

- Un-install the old hinges; they are no longer necessary, the custom door panel will be mounted on the appliance door.

All necessary parts are included with the appliance or can be ordered from Miele.

Dimensions

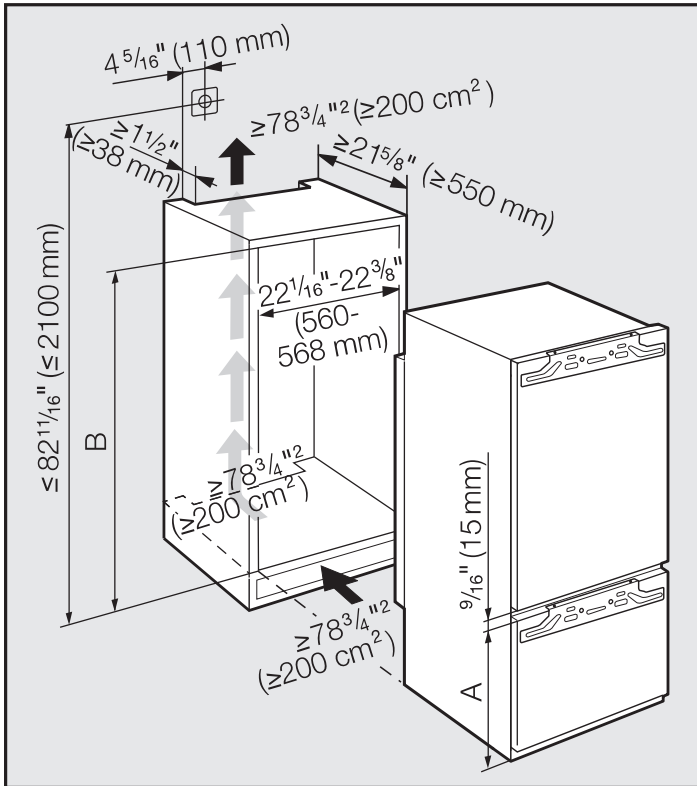

	Freezer section height (A)	Niche height (B)
KFN 9755 iDE	27 3/8" (695 mm)	69 3/4" - 70 3/8" (1772 mm - 1788 mm)

Adjusting the door hinges

The door hinges are pre-adjusted so that the appliance doors can be opened wide.

However, if the opening angle of the door needs to be limited for any reason the hinges can be adjusted to accommodate this.

For example, if the appliance door hits an adjacent wall when opened, the opening angle can be limited to 90°.

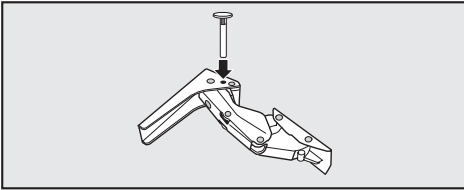

- Insert the locking pins (supplied) into the hinges from above.

This will limit the opening angle of the appliance door to 90°.

Adjusting the door hinges

Before installing the appliance, you will need to decide which side of the door you would like hinged. For an and left-handed door hinge, follow the instructions below.

Tools needed:

- a Philips head screwdriver,
 - a flathead screwdriver,
 - various sizes of Torx screwdrivers,
 - an open-ended wrench.
- Open the appliance doors.

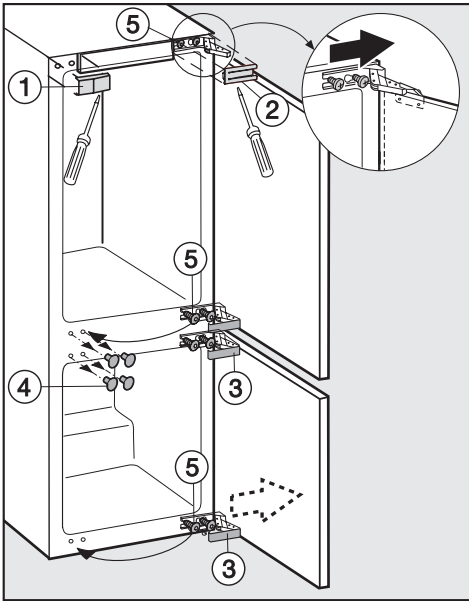

- Using a flathead screwdriver, lift and remove the covers ①, ② and ③, as well as the plugs ④.

- Slightly loosen the fastening screws ⑤ at the top, middle and bottom.
- Slide the appliance doors outwards and unhinge them.
- Completely unscrew the fixing screws ⑤.
- Loosely screw them into the top, middle and bottom of the opposite side of the appliance.

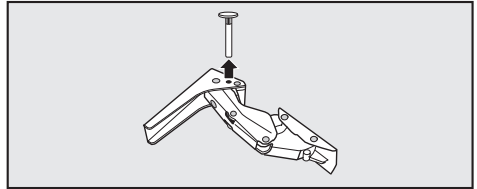

- Pull the pins up and out of the hinges (if necessary).

Adjusting the door hinges

Removing the door damper

- With its exterior facing downwards, place the appliance door on a stable surface.

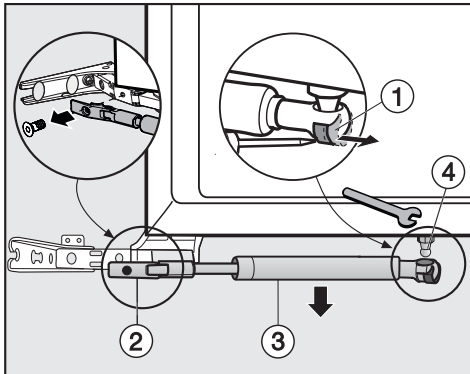

- Carefully push the tension spring ① outward with a screwdriver.

Caution! When uninstalled the door damper will snap shut.

- Unscrew the mounting plate ② and remove the door damper ③ downwards.
- Loosen the ball joint ④ using an open ended wrench and remove.

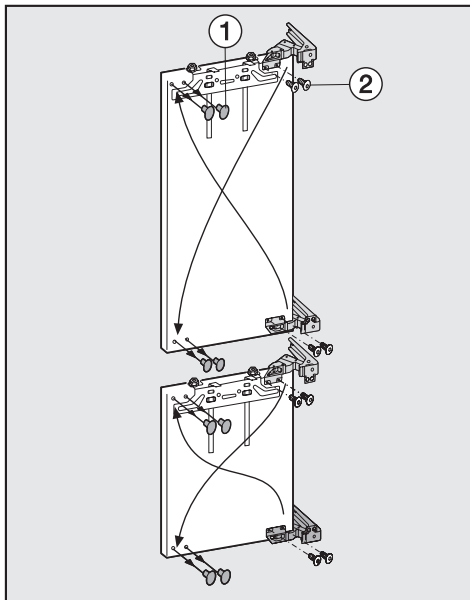

- Stand the appliance doors up individually, and loosen the hinges on the front (hinges remain open).
- Pull out the plugs ① from the top, middle and bottom (if the plugs are not in the doors, they are included separately in the packaging).
- Remove the screws from all the hinges ②.
- Relocate each hinge diagonally in the opposite corner.

Do **not** close the hinges.
Risk of injury!

- To tighten the hinges, use a power screwdriver – the screws ② are self-tapping.
- Use the plugs ① to close the holes on the opposite side.

Adjusting the door hinges

Fastening the door damper

- With its exterior facing downwards, again place the appliance door on a stable surface.

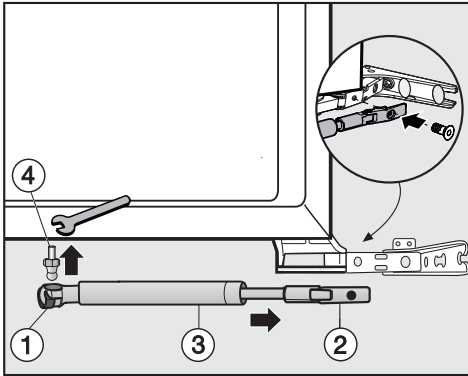

- Screw the ball joint ④ of the door damper ③ to the new mounting hole.
- Push the tension spring ① inward.
- Screw the mounting plate ② onto the hinge.
- Pull open the door damper ③ and secure it to the ball joint ④.

- Hang the appliance doors on the pre-fitted screws and push the doors inward.

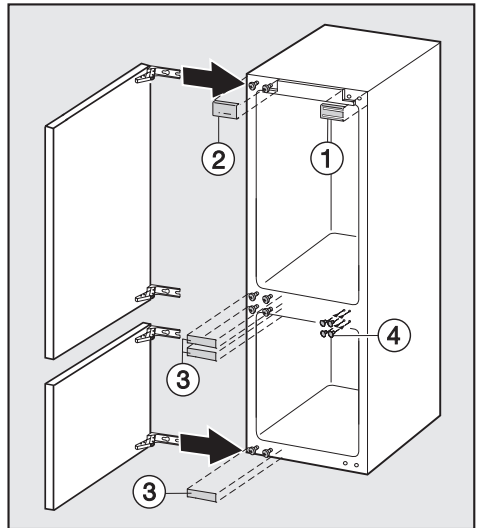

- Tighten the screws at the top, middle and bottom.
- Snap on the covers ①, ② and ③.
- Replace the plugs ④.

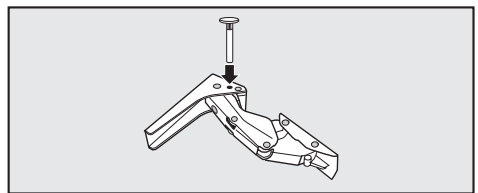

- Insert the pins from above (if necessary).

Installing the appliance

All the installation instructions are for a **right-hinged** appliance door. If you have converted the appliance door to hinge on the left, you will need to adapt the instructions accordingly.

To install the appliance you will need the following tools:

- a Phillips screwdriver,
- various sizes of Torx screwdrivers,
- an Allen key.

Custom door panels

Before mounting the custom doors, ensure that they do not exceed the allowable weight:

Appliance	max. weight upper door	max. weight lower door
KFN 9755	31 lbs	27 lbs
iDE	(14 kg)	(12 kg)

Mounted custom doors that exceed the allowable weight may damage the hinges!

Installing the appliance into a room divider

If you wish to install the appliance in a room divider, the back of the installation space must be fitted with a panel to cover the appliance.

Aligning the housing unit

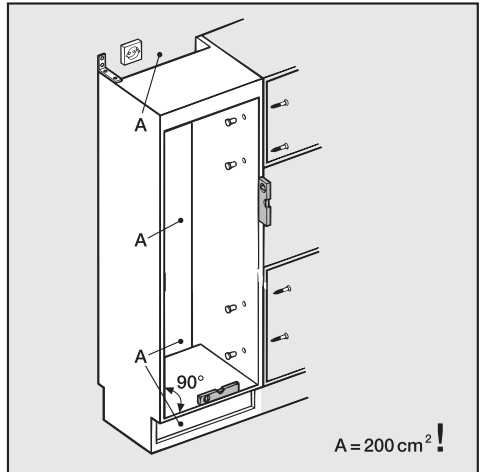

Before installing the appliance, the cabinetry must be carefully aligned using a level. The cabinetry corners have to be 90° angles, otherwise the cabinetry door will not be flush with all 4 corners of the cabinetry.
 $A = 78 \frac{3}{4}''^2 (200 \text{ cm}^2)$

Installing the appliance

Preparing the appliance

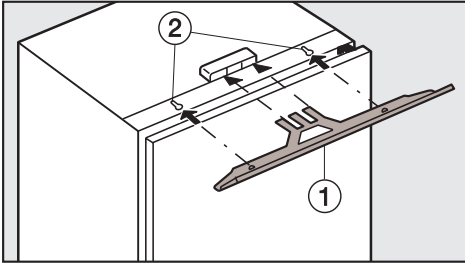

- Push the cover strip ① (with the nubs facing downwards) into the central slot, and use the nubs to hook it into the keyhole slots ②.
- Ensure that the power cord socket remains easily accessible even after the appliance is installed.

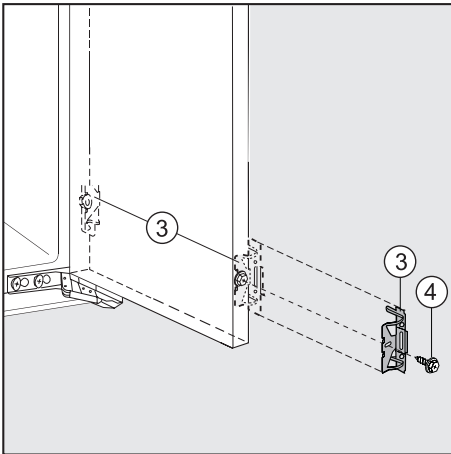

- Screw the supplied mounting brackets ③ into the pre-drilled holes in the appliance doors using a hex screw ④.

(If the cabinetry doors are large, screw on an additional (third) pair of brackets ③ in the area of the door handle.)

- Push the appliance two-thirds of the way into the installation space. Ensure that the power cord does not get caught.

For 5/8" (16 mm) cabinetry walls only:

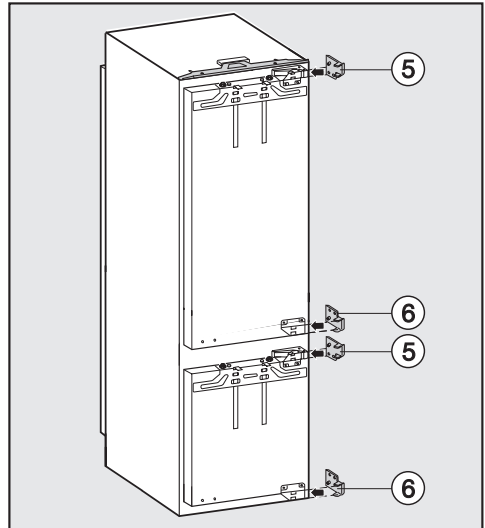

- Clip the spacers ⑤ and ⑥ onto the top and bottom hinges.

Installing the appliance

- Open the appliance doors.

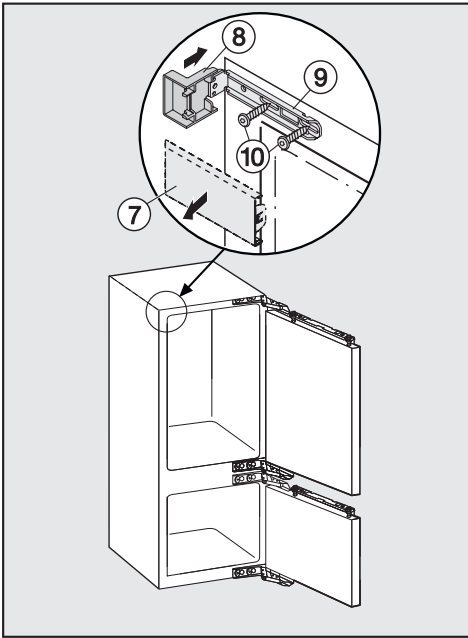

- Use a flat-head screwdriver to remove the cover ⑦ from the upper edge of the appliance.
- Fit the cover ⑧ onto the mounting bracket ⑨.
- Using the screws ⑩ (M5 x 15), screw the mounting angle ⑨ onto the upper part of the appliance.

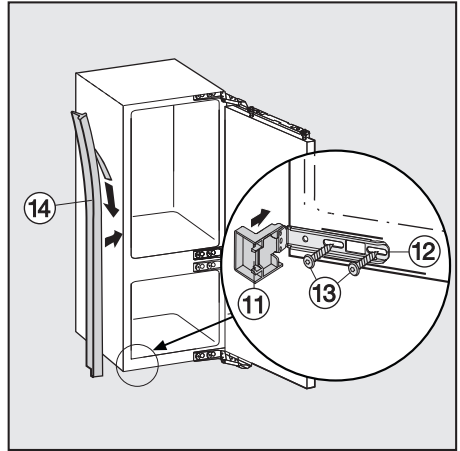

- Fit the cover ⑪ onto the mounting bracket ⑫.
- Using the screws ⑬ (M5 x 15), screw the mounting angle ⑫ onto the lower part of the appliance.
- Pull the protective foil off of the piping strip ⑭.
- Flush-mount the piping strip onto the side of the appliance where the door is opened.
To do so, fit the strip to the lower edge of the upper cover ⑧ and trim it 2 - 3 mm above the lower mounting bracket ⑫.
- Now push the appliance far enough into the installation space that the covers ⑧ and ⑪ are flush with the front edge of the cabinetry side wall.

Installing the appliance

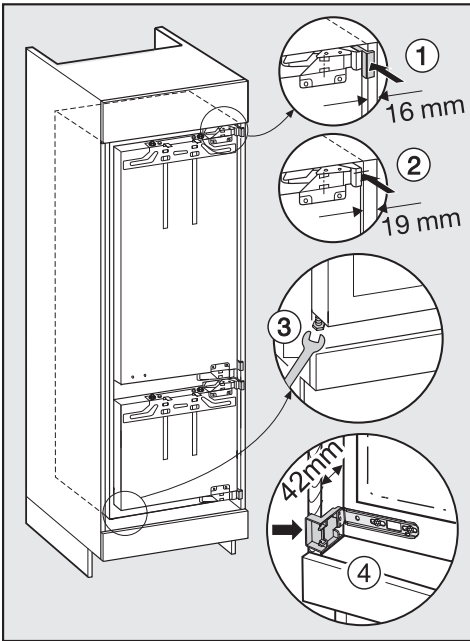

- **For 5/8" (16 mm) cabinetry walls:**
The spacers lie flush on the upper and lower front edge of the cabinetry side wall ①.
- **For 3/4" (19 mm) cabinetry walls:**
The front edges of the hinges above and below are flush with the front edge of the cabinetry side wall ②.
- Check again to see whether the covers on the upper and lower mounting brackets are lying on the front edge of the cabinetry side wall ④.

This will help to maintain a **1 5/8" (42 mm)** distance all the way around from the front edges of the cabinetry side walls.

For furniture with parts along the door hinge (such as nubs, seals, etc.) the installed dimensions of the hinge parts must be taken into account, so that a distance of **42 mm** is maintained all the way around.

- Pull the appliance forward the appropriate amount to suit the installed dimensions.

The hinges and covers will now be positioned to suit the dimensions.

Tip: Remove the door hinge parts. This will allow the surrounding cabinetry doors to lie flush.

If a circumferential distance of 1 5/8" (42 mm) (from the body of the appliance to the front side of the cabinetry side wall) is not maintained, the appliance door may not close properly. This can cause icing, condensation and malfunctions.

- Use the fork wrench to adjust the feet as needed, so that the appliance is level ③.

Installing the appliance

Securing the appliance to the space

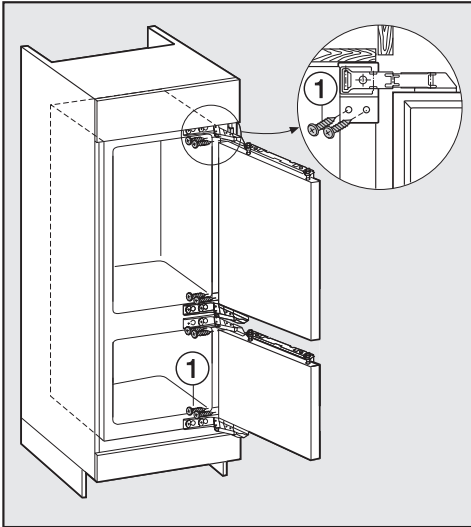

- Push the hinged side of the appliance to the cabinetry wall.
- To secure the appliance at the top and bottom to the cabinetry, screw the long particle board screws ① 3/16" x 13/16" (4 x 20 mm) through the upper and lower hinge flaps.

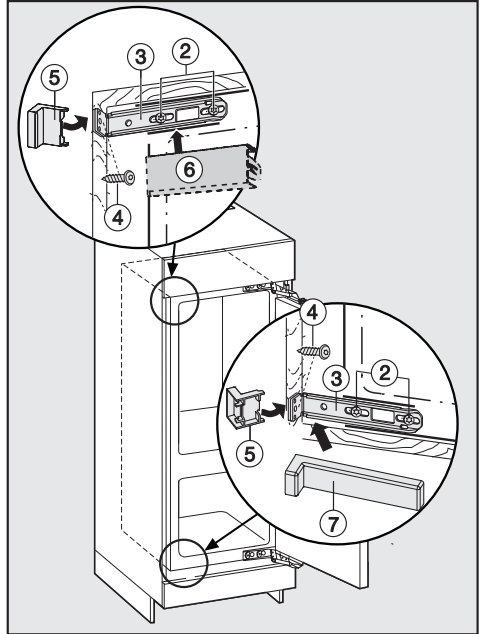

- Slightly loosen the screws ② on the upper and lower mounting brackets ③.
- Push the mounting brackets ③ against the cabinetry wall, and tighten the screws ② back in.
- Using the screws ④, tighten the mounting brackets ③ into the cabinetry wall. You may wish to pre-drill the holes in the cabinetry wall.
- Snap off the excess from the upper cover ⑤ and flip it over onto the upper mounting bracket ③.
- Fit the long cover ⑥ onto the upper mounting bracket ③.

Installing the appliance

- Snap off the excess from the lower cover ⑤. It is no longer needed.
- Fit the bracket cover ⑦ onto the lower mounting bracket ③.
- Close the appliance doors.

Mounting the cabinetry doors

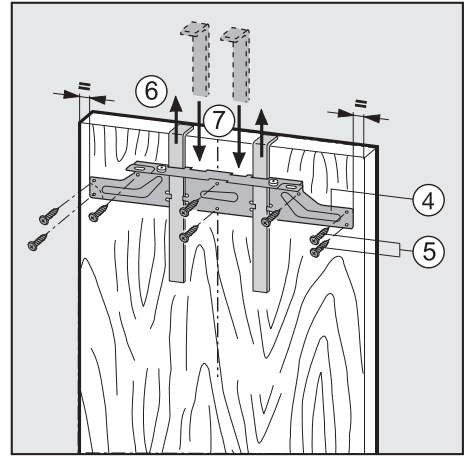
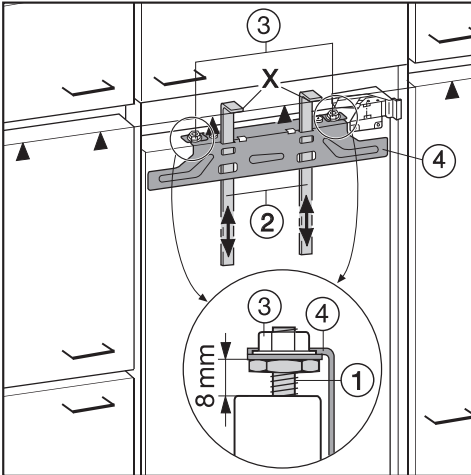

- Adjust the space between the appliance door and the mounting rail to 5/16" (8 mm) ①.
- Slide the mounting aids ② to the height of the cabinetry door: The lower limiting edge X of the mounting aids must be at the same height as the upper edge of the cabinetry door to be mounted, symbol ▲.
- Unscrew the nuts ③ and remove the mounting rail ④ along with the mounting aids.
- With a pencil, draw a thin line on the center of the inside of the cabinetry door.
- Use the mounting aids to hang the mounting rail ④ on the **inside** of the cabinetry door. Align the mounting rail in the middle.
- Screw on the mounting rail with at least 6 short particle-board screws ⑤ 3/16" x 9/16" (4 x 14 mm). (For cassette doors, use only 4 screws at the edge).
- Carefully pull the mounting aids up and out ⑥.
- Turn the mounting aids and completely insert them (for safekeeping) into the middle slits of the mounting rail ⑦.

Installing the appliance

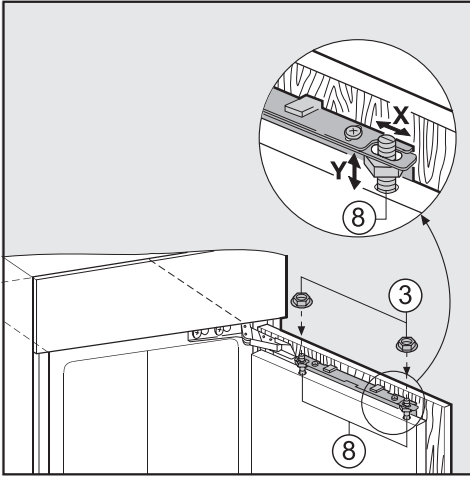

- Hang the cabinet door on the adjustment bolts (8).
- Screw the nuts (3) loosely onto the adjustment bolts.
- Close the door and check the door clearance to the adjacent cabinet doors.
- Align the cabinet door with the adjacent cabinet doors:
For side alignment X, move the cabinet door, and for height alignment Y, turn the adjustment bolts (8) using a flat-head screwdriver.
- Tighten the nuts (3).

Screw the appliance door and cabinet door together:

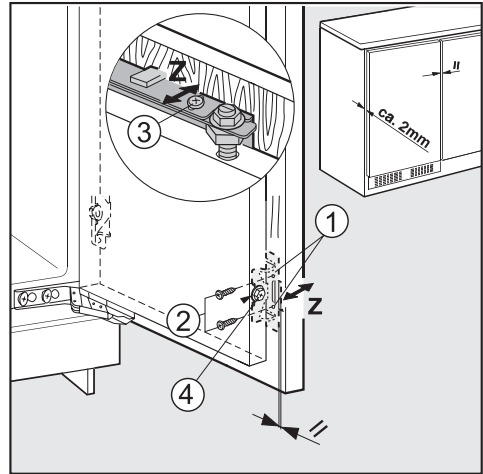

- Pre-drill the mounting holes (1) in the appliance door, and screw in the screws (2) 3/16" x 9/16" (4 x 14 mm). See that both metal edges are flush (symbol //).
- Align the cabinet door depth Z:
Unscrew the screws at the top of the appliance door (3) and the screw at the bottom of the mounting angle (4). Adjust the cabinet door to create a space of 2 mm between the cabinet door and the cabinet body.

Installing the appliance

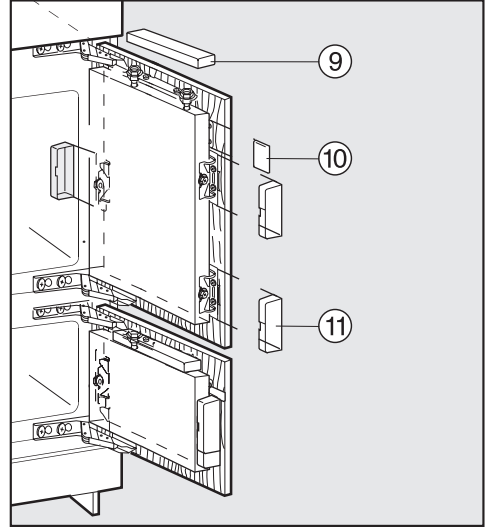
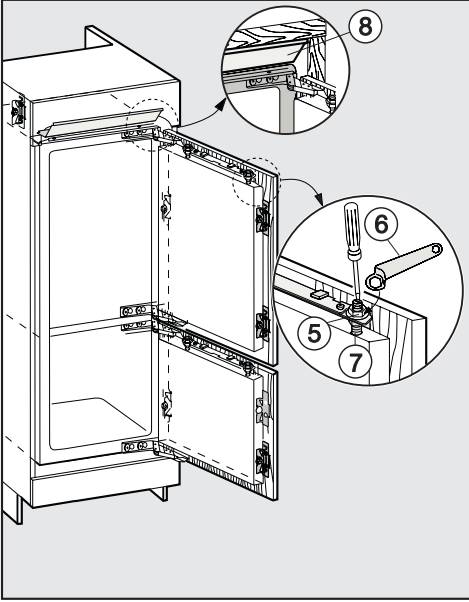

- Close both the doors and align them to the adjacent cabinetry doors.
- Tighten the nuts ⑤ on the appliance doors using a combination wrench ⑥ while holding the adjustment bolts ⑦ still with a flathead screwdriver.
- The cover strip ⑧ must not protrude, it must be completely inside in the installation space.
- Tighten all the screws again.
- Click each top cover ⑨ into place.
- Click the side covers ⑩ into place.
- Click the covers ⑪ on the sides into place.

Installing the appliance

Check the following to confirm that the appliance has been correctly installed:

- The doors close properly.
- The doors do not touch the cabinetry body.
- The seal at the upper corner of the side with the handle contacts tightly.
- To verify this, place a lighted flashlight in the appliance and close the appliance doors. Darken the room and check whether the light is visible at the sides of the appliance. If this is the case, check the individual installation steps again.

**Please have the model and serial number
of your appliance available before
contacting Technical Service.**



**U.S.A.
Miele, Inc.**

National Headquarters

9 Independence Way
Princeton, NJ 08540
Phone: 800-843-7231
609-419-9898
Fax: 609-419-4298
www.mieleusa.com

**Technical Service & Support
Nationwide**

Phone: 800-999-1360
Fax: 888-586-8056

TechnicalService@mieleusa.com

**Canada
Miele Limited**

Headquarters and Showroom

161 Four Valley Drive
Vaughan, ON L4K 4V8
Phone: 800-643-5381
905-660-9936
Fax: 905-532-2290
www.miele.ca
professional@miele.ca
(commercial enquiries)

MieleCare National Service

Phone: 800-565-6435
905-532-2272
Fax: 905-532-2292
customercare@miele.ca
(general and technical enquiries)

Germany

Miele & Cie. KG
Carl-Miele-Straße 29
33332 Gütersloh

