

## 36" All Gas Range with Griddle

HR 1136 G GD, HR 1136 LP GD



# 36" All Gas Range with Griddle

## Model: HR 1136 G GD / HR 1136 LP GD



### HR 1136 G GD / HR 1136 LP GD

#### Features:

- DirectSelect controls
- M Pro dual stacked burner system with TrueSimmer
- M Pro infrared griddle
- ComfortClean dishwasher-safe grates
- 5 Operating modes including Self-Clean
- Twin Convection fans
- Soft Open and Soft Close
- Clean Touch Steel™ front

#### SPECIFICATIONS

HR 1136 G GD	Item 25113651USA
HR 1136 LP GD	Item 25113652USA
Overall Unit Width	35 <sup>15</sup> / <sub>16</sub> " (913 mm)
Overall Unit Height to Cooktop	35 <sup>1</sup> / <sub>2</sub> " – 37" (901.7 – 939.8 mm)
Overall Unit Depth to Front of Control Panel	26 <sup>1</sup> / <sub>2</sub> " (673 mm)
Oven Door Clearance	22 <sup>3</sup> / <sub>4</sub> " (577 mm)
<b>Niche</b>	
Minimum Cabinet Niche Width	36" (914 mm)
Minimum Cabinet Opening Height	35 <sup>1</sup> / <sub>2</sub> " (901.7 mm)
<b>Burners (G/LP)</b>	
Gas Burners:	(1) 12,500 BTU (G/LP); (3) 19,500 BTU (G/LP)
Griddle:	(1) 13,000 BTU (G); 14,300 BTU (LP)
Total BTU Output	84,000 BTU (G); 85,300 BTU (LP)
<b>Oven Burners (G/LP)</b>	
Oven Top Burner:	22,000 BTU (G); 20,150 BTU (LP)
Oven Bottom Burner:	25,500 BTU (G); 27,000 BTU (LP)
<b>Gas</b>	
Gas Line Connection	1/2" NPT
<b>Operational Altitudes</b>	
High Altitude	<p>Miele Natural Gas and LP Ranges and Rangetops will function up to 9,800 ft. in altitude without adjustment; the following exception will function up to 6,500 ft. in altitude without adjustment:</p> <ul style="list-style-type: none"> <li>• Griddle in LP: HR 1136 LP, HR 1936 LP, HR 1956 LP, KMR 1136 LP, KMR 1356 LP</li> <li>• Grill in G: HR 1135 G, HR 1935 G, HR 1955 G, KMR 1135 G, KMR 1355 G</li> </ul> <p>If an installation exceeds these elevations, please contact <a href="mailto:rangejetkit@mieleusa.com">rangejetkit@mieleusa.com</a>.</p>
<b>Electrical</b>	
Electrical Requirements	120V, 60Hz, 15 Amps
Power Cord	NEMA 5-15 plug, 5' 11" (1.8 m) long
<b>Shipping</b>	
Shipping Weight	448.6 lbs (203.5 kg)
Shipping Dimensions	43 <sup>5</sup> / <sub>16</sub> " (1100 mm) W x 52" (1,294 mm) H x 31 <sup>1</sup> / <sub>2</sub> " (800 mm) D
<b>Support</b>	
Call Miele	800.843.7231
Miele Website	<a href="http://www.mieleusa.com">www.mieleusa.com</a>
20/20 Link	<a href="http://2020technologies.com">2020technologies.com</a>

\* Please note if a BTU-reducing kit is necessary, an authorized installer is required to modify the product to meet ANSI Z21.

# 36" All Gas Range with Griddle

Model: HR 1136 G GD / HR 1136 LP GD



## Optional Accessories:



12" Backguard  
RBGAG1236

12" tall high-quality brushed stainless steel Backguard



20" Backguard  
RBGAG2036

20" tall high-quality brushed stainless steel Backguard



40" Backsplash  
RBS36

40" tall flat stainless steel Backsplash panel

# 36" All Gas Range with Griddle

## Model: HR 1136 G GD / HR 1136 LP GD



### PRODUCT VIEWS

Isometric

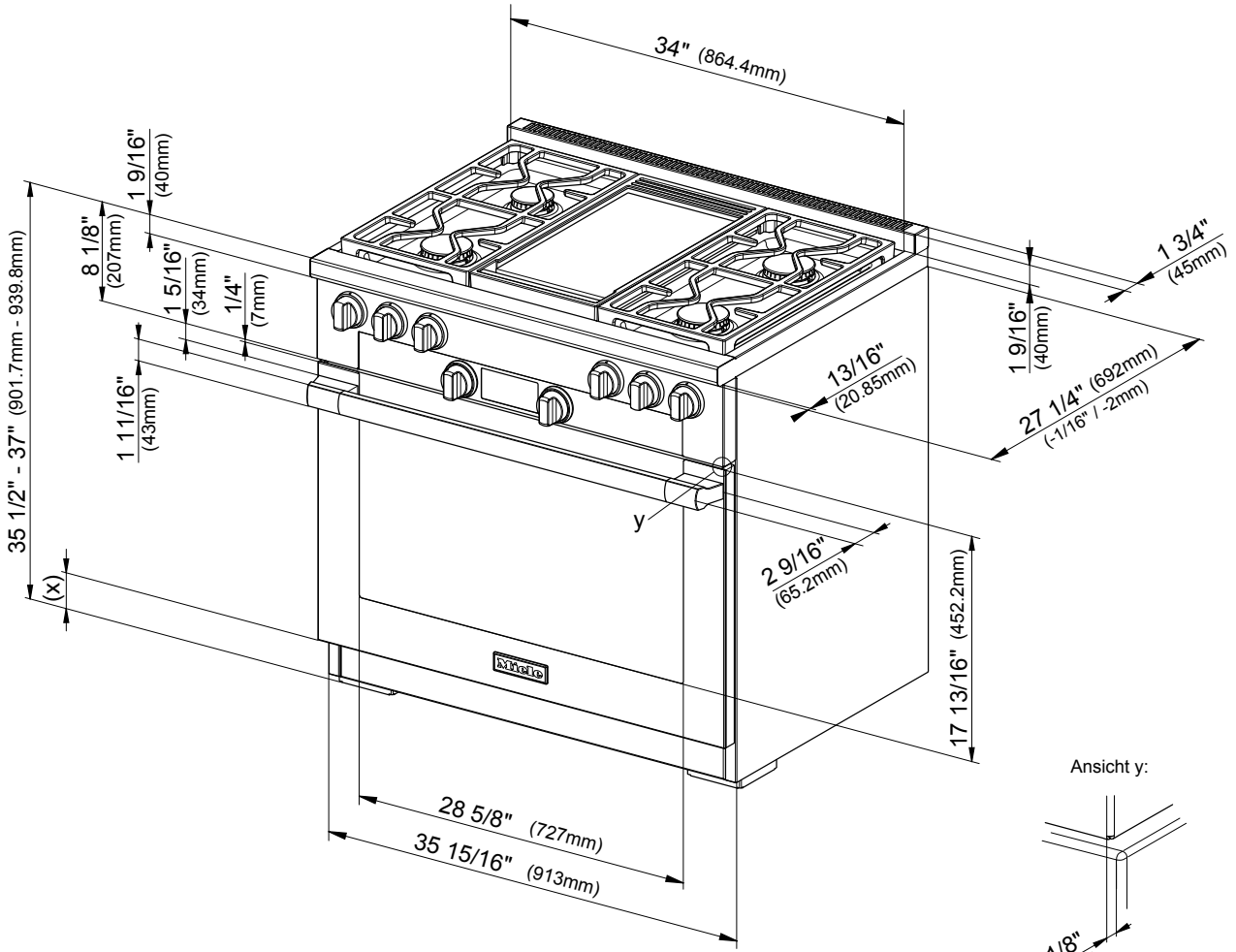

(x) = Toe-kick height adjustment 5" - 6 1/2" (127 mm - 165.1 mm)

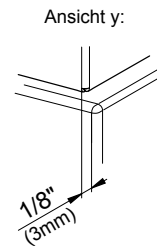

# 36" All Gas Range with Griddle

Model: HR 1136 G GD / HR 1136 LP GD



## PRODUCT VIEWS

Rear View

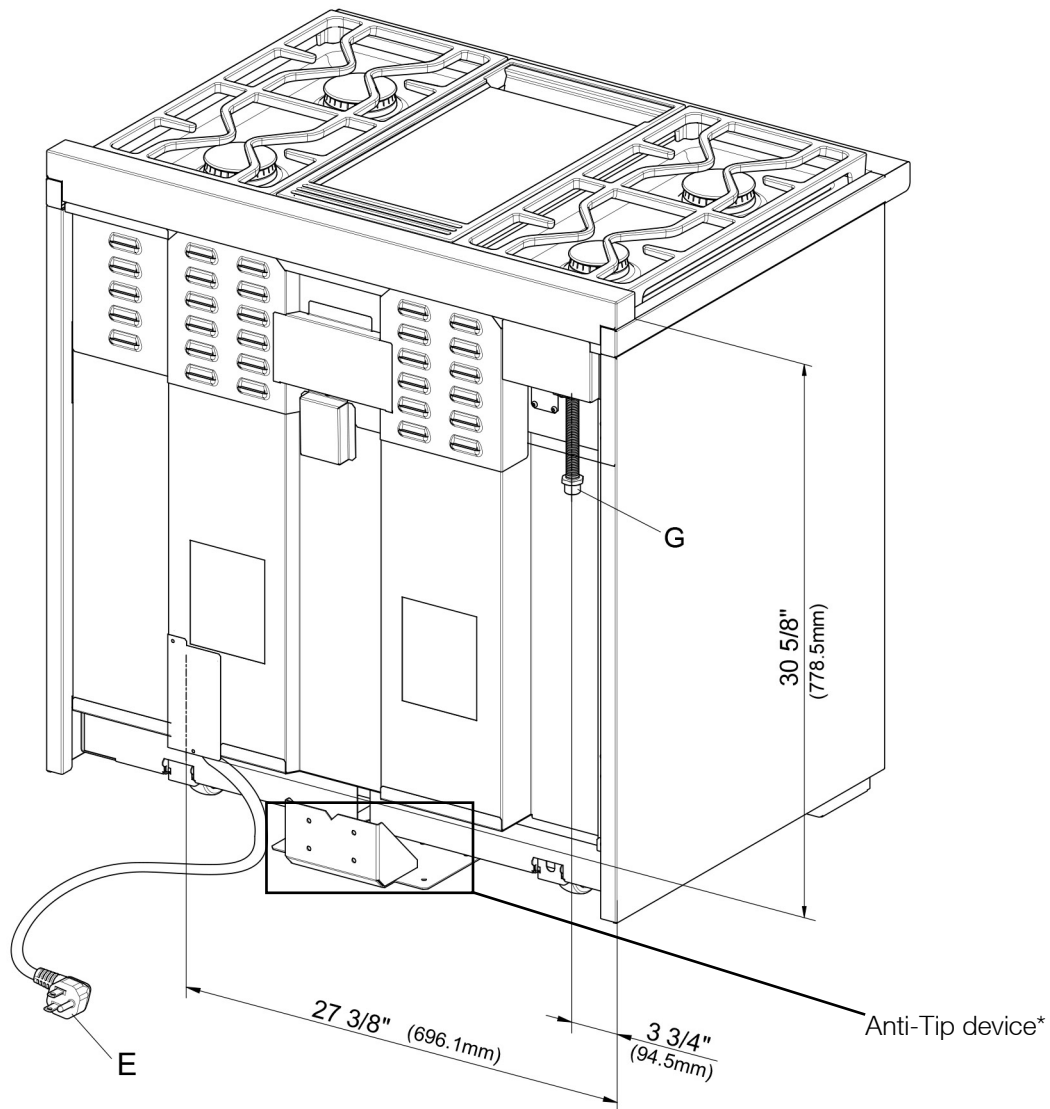

E = Electrical connection

G = Gas connection

\*Anti-tip device must be fastened securely in place to all studs or floor. Please refer to the Anti-tip device section in the installation manual for further details.

# 36" All Gas Range with Griddle

## Model: HR 1136 G GD / HR 1136 LP GD



### PRODUCT VIEWS

#### Detailed Side View

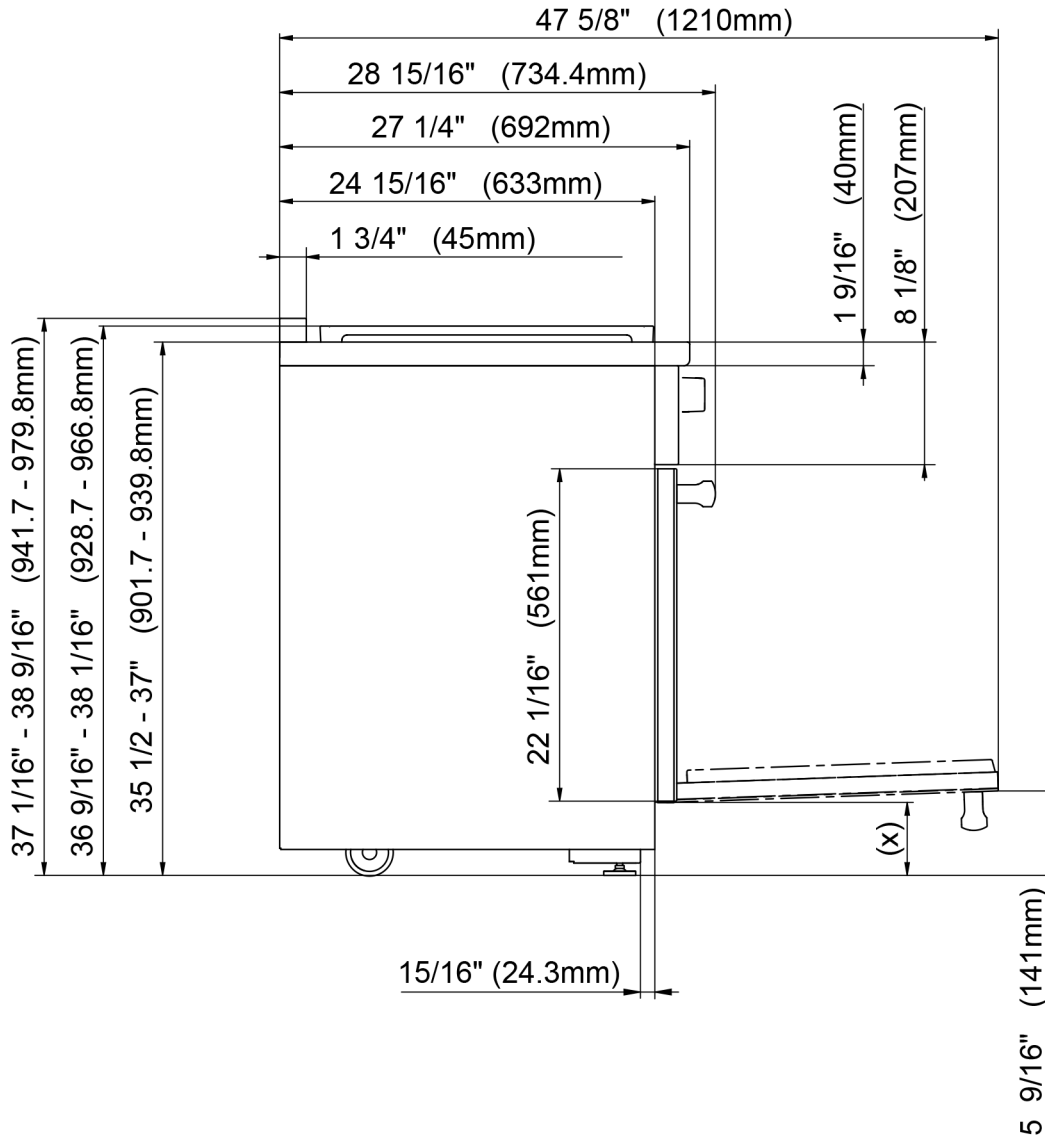

(x) = Toe-kick height adjustment 5" - 6 1/2" (127 mm - 165.1 mm)

# 36" All Gas Range with Griddle

Model: HR 1136 G GD / HR 1136 LP GD



## PRODUCT VIEWS

Detailed Bullnose and Handle View

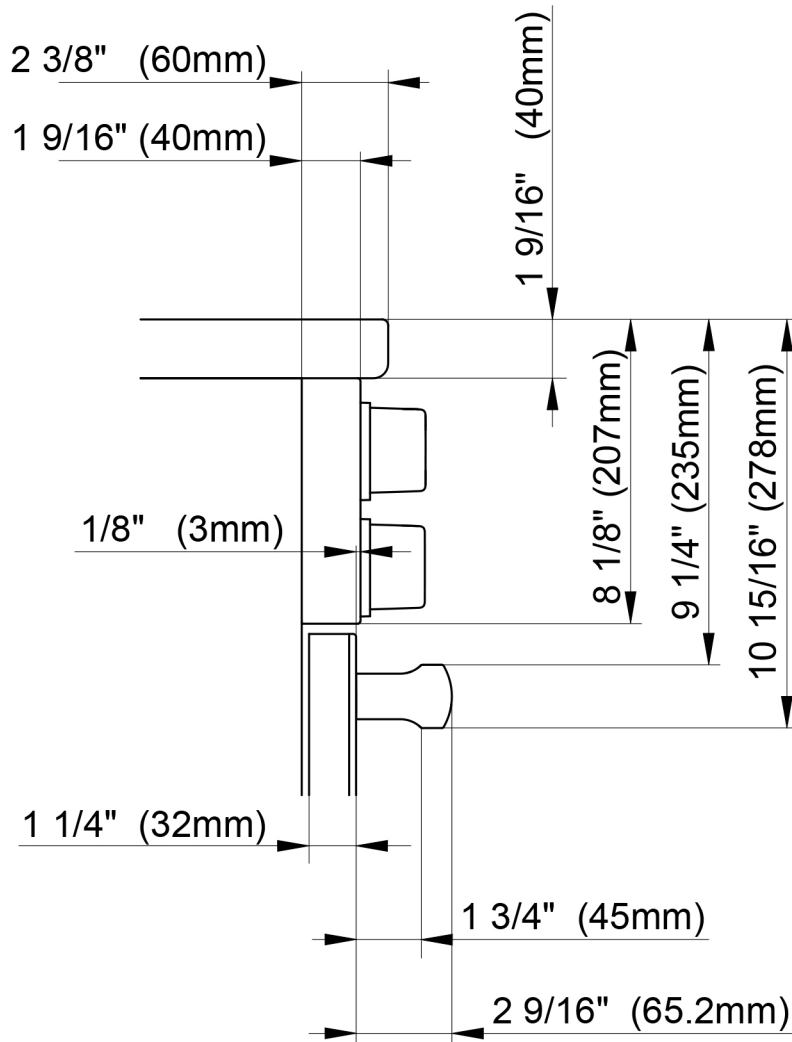



# 36" All Gas Range with Griddle

## Model: HR 1136 G GD / HR 1136 LP GD



### M Pro Power Plus Configuration

Standard Configuration with Pro Hood\*

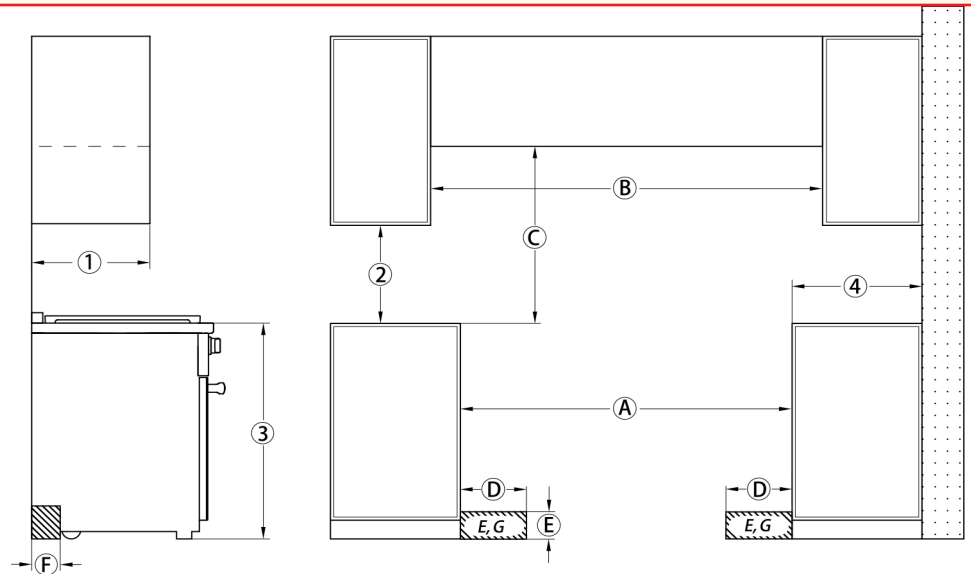

Ⓑ In case of combustible materials, a minimum distance of 6" must be observed on each side in addition to dimension Ⓐ.

Ⓓ, Ⓔ, Ⓕ The shaded area represents the installation area for the connections:  
E = Electrical connection, G = Gas connection

#### M Pro Power Plus SPECIFICATIONS

##### Burners (G/LP)

Gas Burners:	(1) 12,500 BTU (G/LP); (3) 19,500 BTU (G/LP)
Griddle:	(1) 13,000 BTU (G); (1) 14,300 BTU (LP)
Total BTU Output	84,000 BTU (G); 85,300 BTU (LP)

Position	Dimensions	Description	
Ⓚ	13" (330 mm)	Maximum depth of top cabinet	
Ⓛ	18" (457 mm)	Minimum distance to bottom edge of top cabinet	
Ⓜ	35 1/2"-37" (901-940 mm)	Distance from the floor to cooktop surface	
Ⓝ	10" (254 mm)	Minimum distance to combustible surfaces.	
Ⓐ	Min. 36" (914 mm)	Width of cabinet opening	
Ⓑ	6" + Ⓐ + 6" (150 mm + Ⓐ + 150 mm)	If combustible materials are present, an additional minimum distance of 6" (150 mm) (each side) is required. Ensure that the local codes are observed.	
Ⓒ	37" (940 mm)	Minimum distance between the top of the cooking area and the bottom of an unprotected combustible surface.	
	30" (762 mm)	Minimum distance between the top of the cooking area and the bottom of the Miele Range Hood (DAR model with DRxB XL or DRxB XXL blower).	
For all other Hoods please consult the manufacturer's specifications for required distances.			
Ⓓ	Approx. 13 3/4" (350 mm)	Maximum connection width right and left	Position of the wall socket
Ⓔ	Approx. 4 1/2" (115 mm)	Maximum connection height	
Ⓕ	Approx. 2 13/16" (72 mm)	Maximum connection depth	

\* Please note if a BTU-reducing kit is necessary, an authorized installer is required to modify the product to meet ANSI Z21. HR 1136



# 36" All Gas Range with Griddle

Model: HR 1136 G GD / HR 1136 LP GD



## M Pro Power Configuration

Seamless Configuration with Pro Hood (Zero Gap)

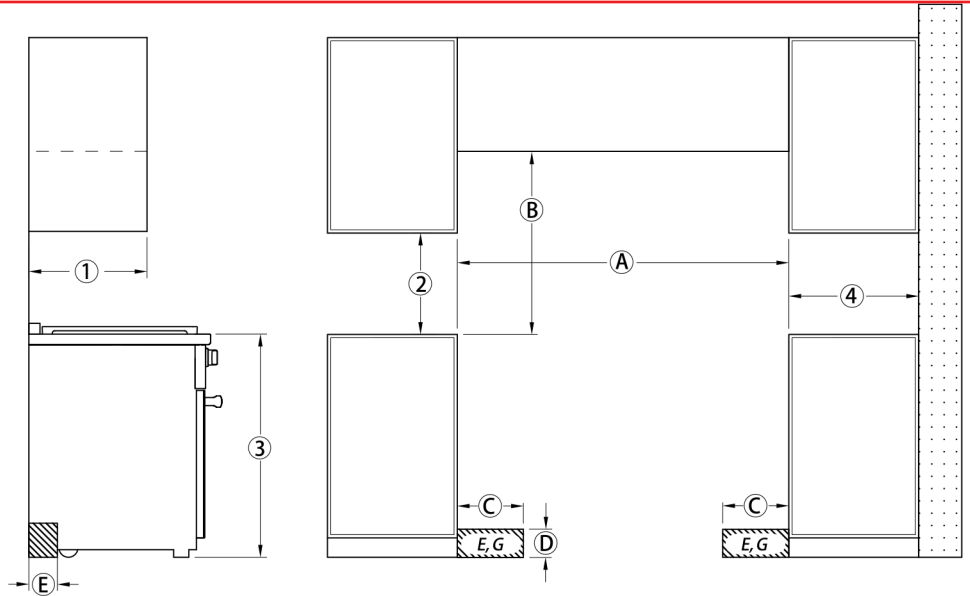

Ⓒ, Ⓓ, Ⓔ The shaded area represents the installation area for the connections:  
E = Electrical connection, G = Gas connection

ZERO-GAP KIT SPECIFICATIONS	
<b>Burners (G/LP)</b>	
Gas Burners:	(1) 10,000 BTU (G/LP); (3) 14,700 BTU (G/LP)
Griddle:	(1) 13,000 BTU (G); (1) 14,300 BTU (LP)
Total BTU Output	67,100 BTU (G); 68,400 BTU (LP)

**Jets are a standard accessory and are changed during installation**

Position	Dimensions	Description	
①	13" (330 mm)	Maximum depth of top cabinet	
②	18" (457 mm)	Minimum distance to bottom edge of top cabinet	
③	35 1/2"–37" (901–940 mm)	Distance from the floor to cooktop surface	
④	10" (254 mm)	Minimum distance to combustible surfaces.	
Ⓐ	Min. 36" (914 mm)	Width of cabinet opening Please contact Miele Service for more information.	
Ⓑ	37" (940 mm)	Minimum distance between the top of the cooking area and the bottom of an unprotected combustible surface.	
	30" (762 mm)	Minimum distance between the top of the cooking area and the bottom of the Miele Range Hood (DAR model with DRxB XL or DRxB XXL blower).	
For all other Hoods please consult the manufacturer's specifications for required distances.			
Ⓒ	Approx. 13 3/4" (350 mm)	Maximum connection width right and left	Position of the wall socket
Ⓓ	Approx. 4 1/2" (115 mm)	Maximum connection height	
Ⓔ	Approx. 2 13/16" (72 mm)	Maximum connection depth	

# 36" All Gas Range with Griddle

Model: HR 1136 G GD / HR 1136 LP GD



## M Pro Configuration

Seamless Configuration with Non-Pro Hood (Décor)

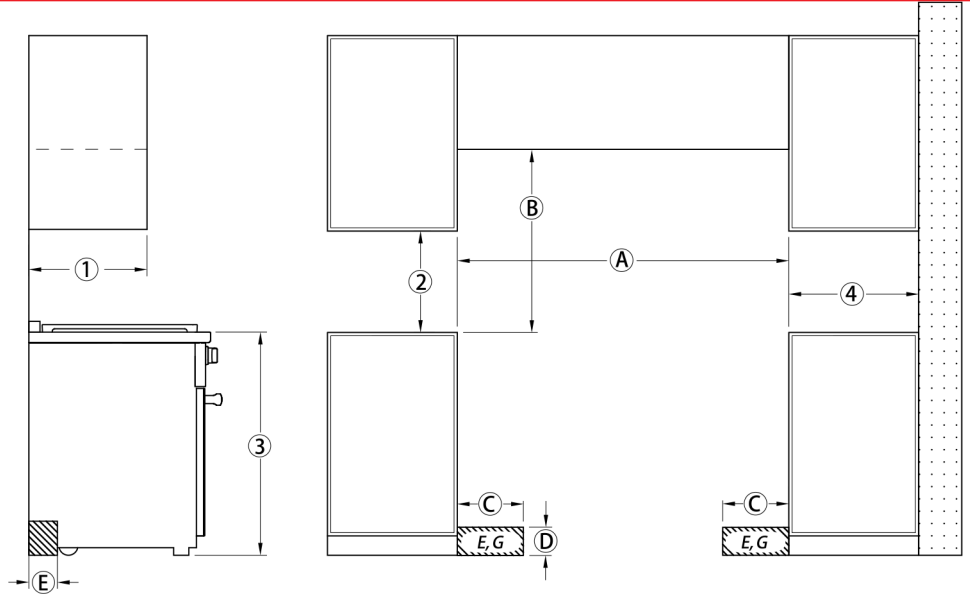

Ⓒ, Ⓓ, Ⓔ The shaded area represents the installation area for the connections:  
E = Electrical connection, G = Gas connection

### M Pro SPECIFICATIONS

#### Burners (G/LP)

Gas Burners: (1) 10,000 BTU (G/LP);  
(3) 12,200 BTU (G/LP)

Griddle: (1) 13,000 BTU (G);  
(1) 14,300 BTU (LP)

Total BTU Output 59,600 BTU (G);  
60,900 BTU (LP)

**Jets are a standard accessory and are changed during installation**

Position	Dimensions	Description	
①	13" (330 mm)	Maximum depth of top cabinet	
②	18" (457 mm)	Minimum distance to bottom edge of top cabinet	
③	35 1/2"-37" (901-940 mm)	Distance from the floor to cooktop surface	
④	10" (254 mm)	Minimum distance to combustible surfaces.	
Ⓐ	Min. 36" (914 mm)	Width of cabinet opening Please contact Miele Service for more information.	
Ⓑ	Please refer to Miele ventilation hood installation manual, Appliance Dimensions section ( <b>Distance between cooktop and hood (S)</b> ) For all other Hoods please consult the manufacturer's specifications for required distances.		
Ⓒ	Approx. 13 3/4" (350 mm)	Maximum connection width right and left	Position of the wall socket
Ⓓ	Approx. 4 1/2" (115 mm)	Maximum connection height	
Ⓔ	Approx. 2 13/16" (72 mm)	Maximum connection depth	