

48" Dual Fuel Range with Grill

HR 1955 DF GR, HR 1955 DF GR LP



48" Dual Fuel Range with Grill

Model: HR 1955 DF GR / HR 1955 DF GR LP



HR 1955 DF GR / HR 1955 DF GR LP

Features:

- M Touch controls and backlit precision knobs
- ComfortLift panel
- M Pro dual stacked burner system with TrueSimmer
- M Pro grill
- ComfortClean dishwasher-safe grates
- TwinPower Convection fans
- 21 Operating modes including Self Clean
- Moisture plus
- MasterChef and MasterChef Plus automatic programs
- Wireless roast probe
- Soft Close and Soft Open
- Clean Touch Steel™ front
- Fully functional M Touch Speed Oven (Combination of Convection Oven and Microwave)
- Fully functional Warming Drawer

SPECIFICATIONS

HR 1955 DF GR	Item 25195551USA
HR 1955 DF GR LP	Item 25195552USA
Overall Unit Width	47 15/16" (1218 mm)
Overall Unit Height to Cooktop	34 ⁹ / ₁₆ " – 36 ¹ / ₁₆ " (877.7 – 915.8 mm)
Overall Unit Depth to Front of Control Panel	26 ¹ / ₂ " (673 mm)
Oven Door Clearance	22 ¹ / ₄ " (565 mm)
Niche	
Minimum Cabinet Niche Width	48" (1219 mm)
Minimum Cabinet Opening Height	35 ¹ / ₂ " – 37" (901.7 – 939.8 mm)
Burners (G/LP)	
Gas Burners:	(2) 12,500 BTU (G/LP); (4) 19,500 BTU (G/LP)
Grill:	(1) 19,000 BTU (G); 15,500 BTU (LP)
Total BTU Output	122,000 BTU (G); 118,500 BTU (LP)
Gas	
Gas Line Connection	1/2" NPT
Operational Altitudes	
	Miele Natural Gas and LP Ranges and Rangetops will function up to 9,800 ft. in altitude without adjustment; the following exception will function up to 6,500 ft. in altitude without adjustment:
High Altitude	<ul style="list-style-type: none"> • Griddle in LP: HR 1136 LP, HR 1936 LP, HR 1956 LP, KMR 1136 LP, KMR 1356 LP • Grill in G: HR 1135 G, HR 1935 G, HR 1955 G, KMR 1135 G, KMR 1355 G <p>If an installation exceeds these elevations, please contact rangejetkit@mieleusa.com.</p>
Plumbing	
	An Inline water filter, like activated carbon, is required to reduce mineral deposits. Do not connect to a Reverse Osmosis (RO) water system. Connect to a cold water supply only. Must be connected to a shut-off valve. The water shut-off valve must be accessible after installation. The water pressure must be between 14.5 and 145 psi (1 and 10 bars). If the pressure is higher, install a pressure-reducing valve. The supplied hose has a length of 9' 10" (3 m). The hose must not be shortened. The total hose length must not exceed 24.5 ft. (7.5 m).
Water Supply Requirements	
Plumbed Hose Connection	Supplied hose: flexible braided 9'10" (3 m) with 3/8" O.D. compression fitting for connection to a shut off valve
Electrical	
Electrical Requirements	120V / 240V, 60Hz, 50 Amps 120V / 208V, 60Hz, 50 Amps
Power Cord	NEMA 14-50 plug, 5' 11" (1.8 m) long
Shipping	
Shipping Weight	617.3 lbs. (280 kg)
Shipping Dimensions	55 ¹ / ₈ " (1400 mm) W x 52" (1,294 mm) H x 31 ¹ / ₂ " (800 mm) D
Support	
Call Miele	800.843.7231
Miele Website	www.mieleusa.com
20/20 Link	2020technologies.com

* Please note if a BTU-reducing kit is necessary, an authorized installer is required to modify the product to meet ANSI Z21.

48" Dual Fuel Range with Grill

Model: HR 1955 DF GR / HR 1955 DF GR LP



Optional Accessories:



12" Backguard
RBGAG1248

12" tall high-quality brushed stainless steel Backguard



20" Backguard
RBGAG2048

20" tall high-quality brushed stainless steel Backguard



40" Backsplash
RBS48

40" tall flat stainless steel Backsplash panel

48" Dual Fuel Range with Grill

Model: HR 1955 DF GR / HR 1955 DF GR LP



PRODUCT VIEWS

Isometric

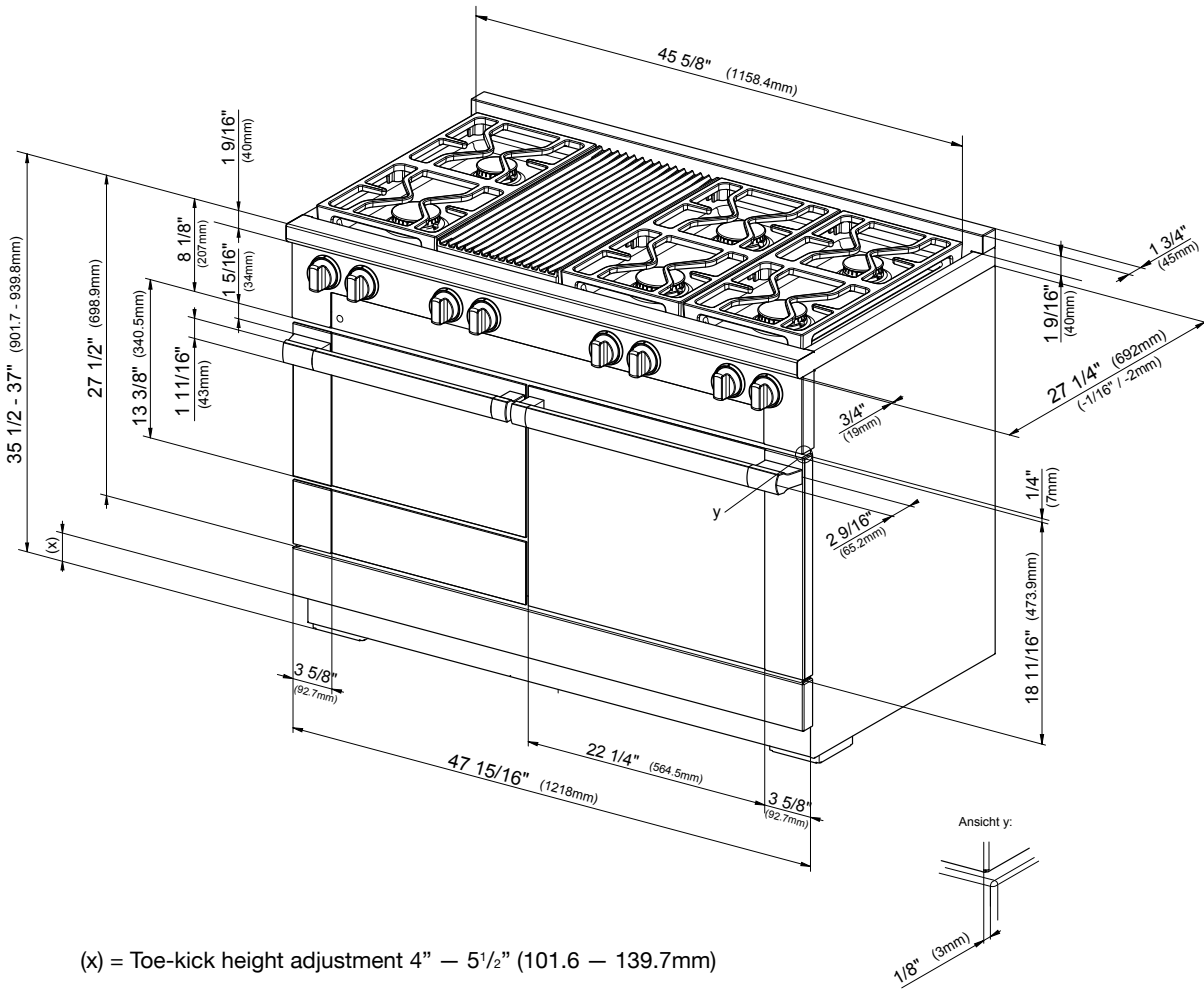

48" Dual Fuel Range with Grill

Model: HR 1955 DF GR / HR 1955 DF GR LP



PRODUCT VIEWS

Rear View

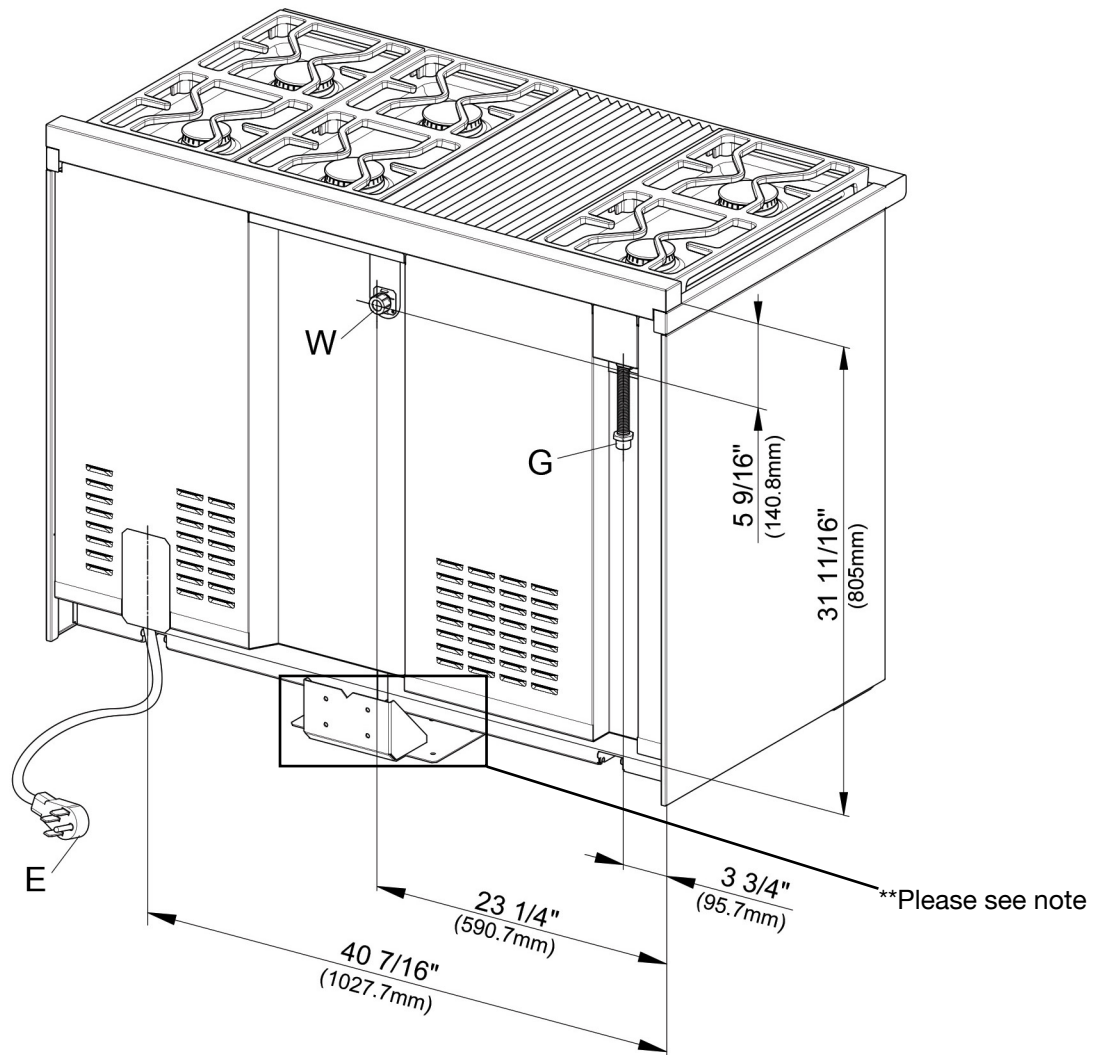

****PLEASE NOTE:** Anti-tip device must be fastened securely in place to all studs or floor. Please refer to the Anti-tip device section in the installation manual for further details.

48" Dual Fuel Range with Grill

Model: HR 1955 DF GR / HR 1955 DF GR LP



PRODUCT VIEWS

Detailed Speed Oven With Warming
Drawer Side View

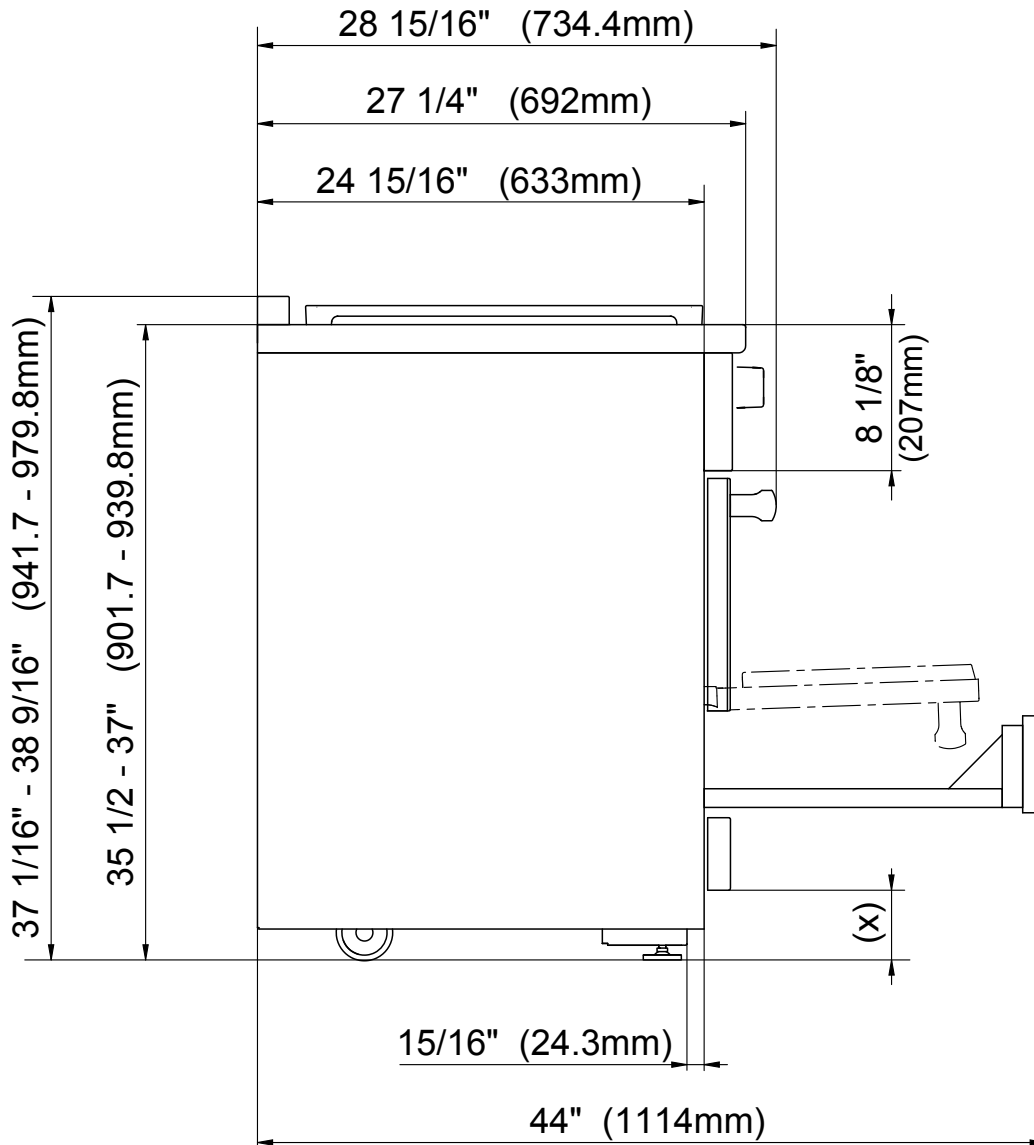

(x) = Depending on the appliance height adjustment: 4" - 5 1/2" (101.6 mm - 139.7 mm)

48" Dual Fuel Range with Grill

Model: HR 1955 DF GR / HR 1955 DF GR LP



PRODUCT VIEWS

Detailed Convection Oven Side View

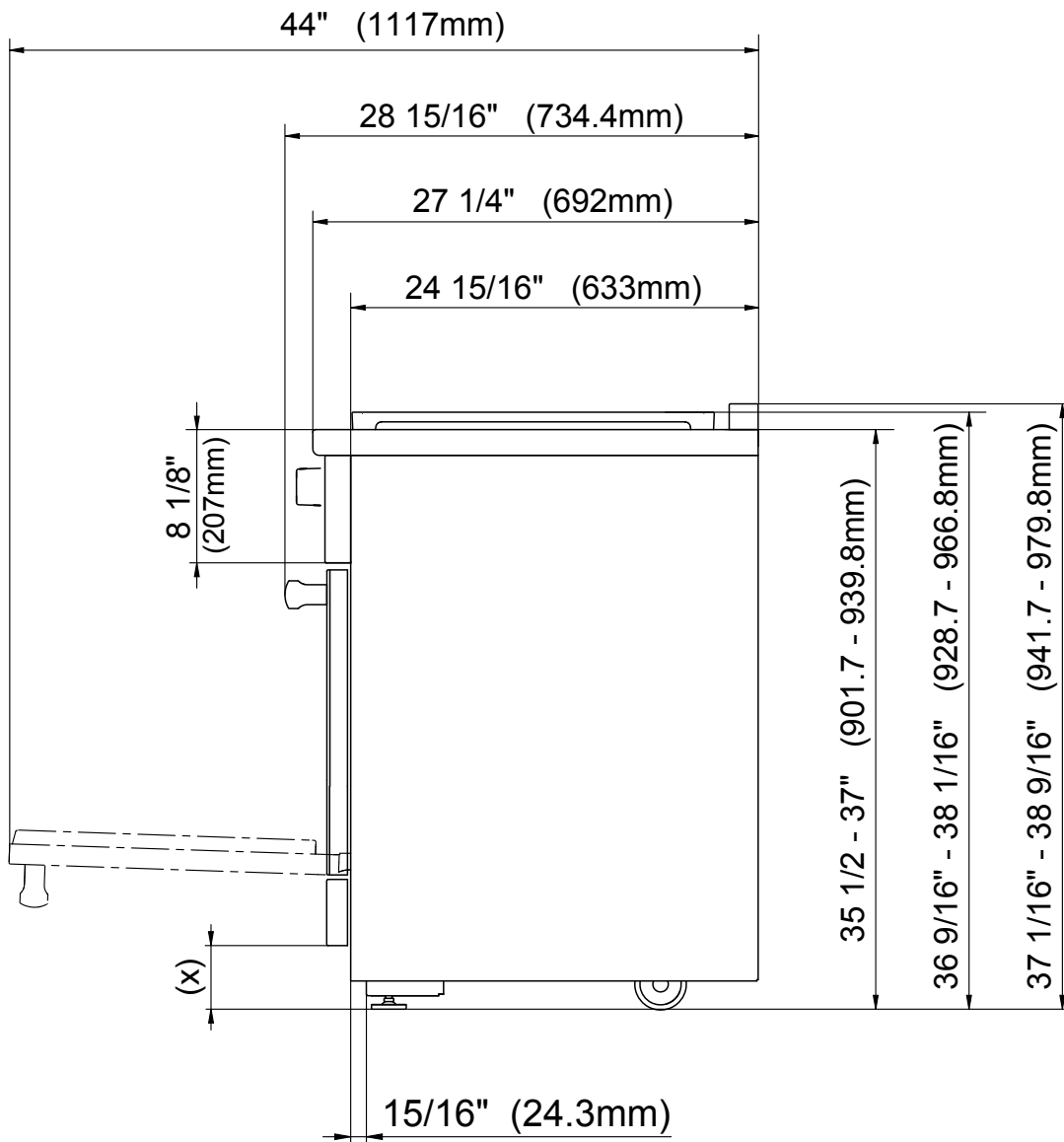

(x) = Depending on the appliance height adjustment: 4" - 5 1/2 " (101.6 mm - 139.7 mm)

48" Dual Fuel Range with Grill

Model: HR 1955 DF GR / HR 1955 DF GR LP



PRODUCT VIEWS

Detailed Bullnose and Handle View

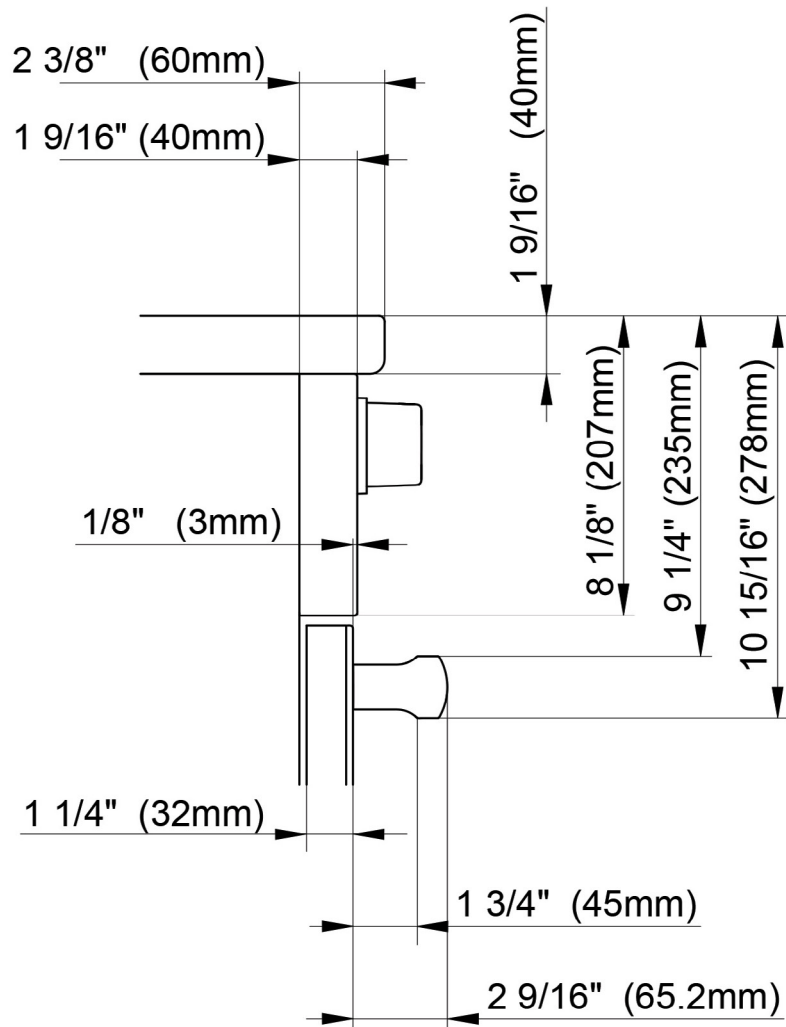

48" Dual Fuel Range with Grill

Model: HR 1955 DF G



M Pro Power Plus Configuration

Standard Configuration with Pro Hood*

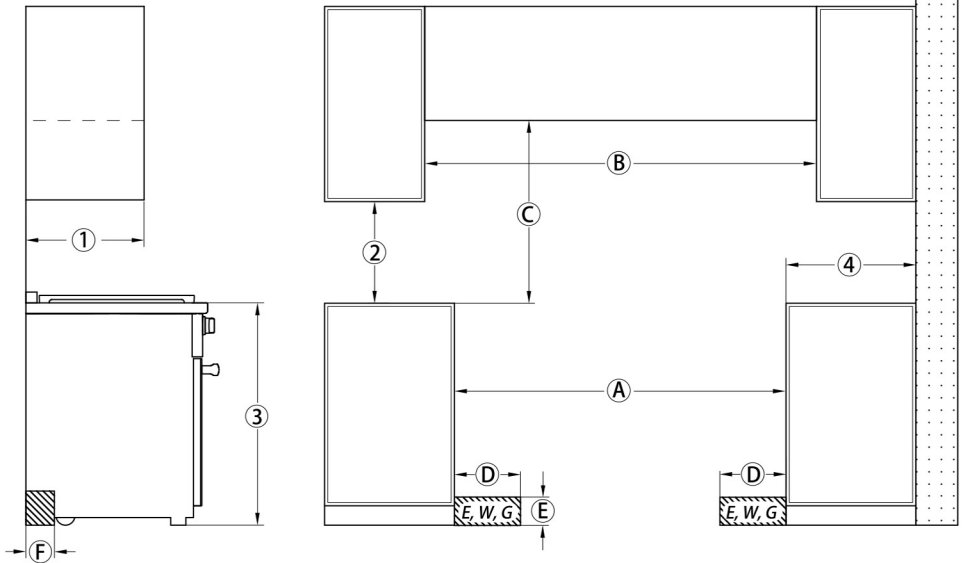

Ⓑ In case of combustible materials, a minimum distance of 6" must be observed on each side in addition to dimension Ⓐ.

Ⓓ, Ⓔ, Ⓕ The shaded area represents the installation area for the connections: E = Electrical connection, W = Water connection, G = Gas connection

M Pro Power Plus SPECIFICATIONS	
Burners (G/LP)	
Gas Burners:	(2) 12,500 BTU (G/LP); (4) 19,500 BTU (G/LP)
Grill:	(1) 19,000 BTU (G); (1) 15,500 BTU (LP)
Total BTU Output	122,000 BTU (G); 118,500 BTU (LP)

Position	Dimensions	Description	
Ⓐ	13" (330 mm)	Maximum depth of top cabinet	
Ⓑ	18" (457 mm)	Minimum distance to bottom edge of top cabinet	
Ⓒ	35 1/2"–37" (901–940 mm)	Distance from the floor to cooktop surface	
Ⓓ	10" (254 mm)	Minimum distance to combustible surfaces.	
Ⓐ	Min. 48" (1219 mm)	Width of cabinet opening	
Ⓑ	6" + Ⓐ + 6" (150 mm + Ⓐ + 150 mm)	If combustible materials are present, an additional minimum distance of 6" (150 mm) (each side) is required. Ensure that the local codes are observed.	
Ⓒ	37" (940 mm)	Minimum distance between the top of the cooking area and the bottom of an unprotected combustible surface.	
	36" (914 mm)	Minimum distance between the top of the cooking area and the bottom of the Miele Range Hood (DAR model with DRxB XXL blower).	
For all other Hoods please consult the manufacturer's specifications for required distances.			
Ⓓ	Approx. 20 1/2" (518 mm)	Maximum connection width right and left	Position of the wall socket
Ⓔ	Approx. 3 1/2" (90 mm)	Maximum connection height	
Ⓕ	Approx. 2 13/16" (72 mm)	Maximum connection depth	

From the back side of the cooktop, a 12" (305 mm) minimum distance to the combustible rear wall above the countertop is required.

* Please note if a BTU-reducing kit is necessary, an authorized installer is required to modify the product to meet ANSI Z21.

48" Dual Fuel Range with Grill

Model: HR 1955 DF GR / HR 1955 DF GR LP



M Pro Power Configuration

Seamless Configuration with Pro Hood (Zero Gap)

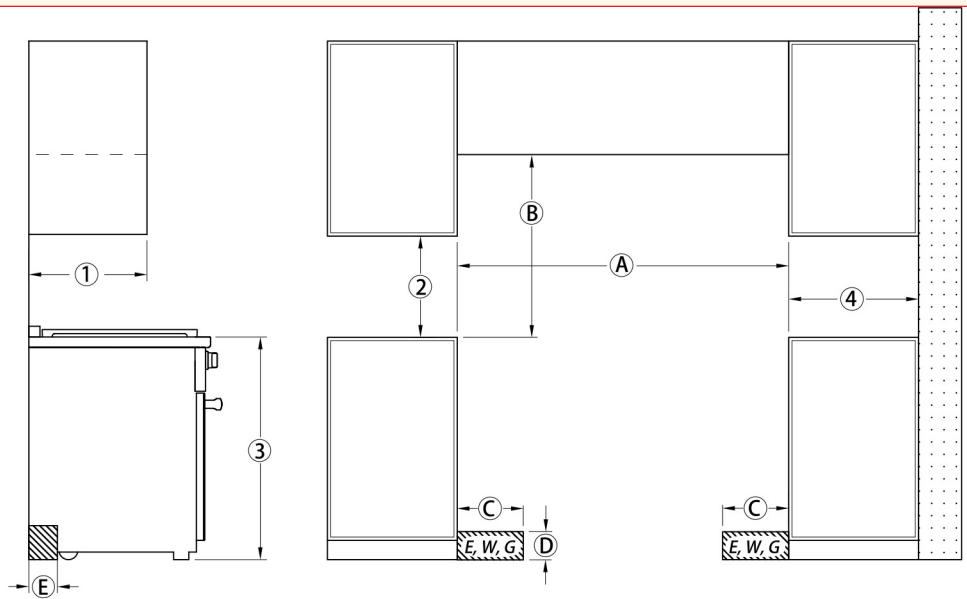

M Pro Power SPECIFICATIONS

Burners (G/LP)

Gas Burners: (2) 10,000 BTU (G/LP); (4) 14,700 BTU (G/LP)

Grill: (1) 19,000 BTU (G); (1) 15,500 BTU (LP)

Total BTU Output 97,800 BTU (G); 94,300 BTU (LP)

Jets are a standard accessory and are changed during installation

©, ©, © The shaded area represents the installation area for the connections:
E = Electrical connection, W = Water connection, G = Gas connection

Position	Dimensions	Description	
①	13" (330 mm)	Maximum depth of top cabinet	
②	18" (457 mm)	Minimum distance to bottom edge of top cabinet	
③	35 1/2"–37" (901–940 mm)	Distance from the floor to cooktop surface	
④	10" (254 mm)	Minimum distance to combustible surfaces.	
Ⓐ	Min. 48" (1219 mm)	Width of cabinet opening Please contact Miele Service for more information.	
Ⓑ	37" (940 mm)	Minimum distance between the top of the cooking area and the bottom of an unprotected combustible surface.	
	36" (914 mm)	Minimum distance between the top of the cooking area and the bottom of the Miele Range Hood (DAR model with DRxB XXL blower).	
For all other Hoods please consult the manufacturer's specifications for required distances.			
©	Approx. 20 1/2" (518 mm)	Maximum connection width right and left	Position of the wall socket
©	Approx. 3 1/2" (90 mm)	Maximum connection height	
©	Approx. 2 13/16" (72 mm)	Maximum connection depth	

From the back side of the cooktop, a 12" (305 mm) minimum distance to the combustible rear wall above the countertop is required.