

MasterCool Refrigeration  
Side-by-Side Merging Combinations  
For SF Models

KSK 1003

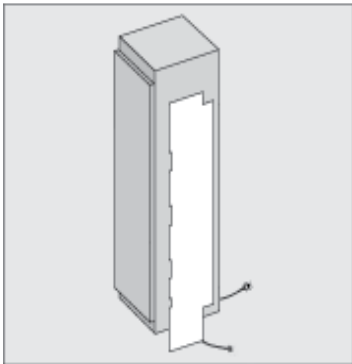

# Side-by-Side Merging Kit KSK 1003



## SPECIFICATIONS

KSK 1003 — Item 10562720

### Electrical

Power Cord Direct connection to left-standing appliance

### Support

Call Miele (800) 999-1360

Miele Website [www.mieleusa.com](http://www.mieleusa.com)

20/20 Link [2020technologies.com](http://2020technologies.com)

This merging kit should be used for side-by-side installation of the following models:

- K 18x1 SF, K 19x1 SF, K 18x3 SF, K 19x3 SF
- F 14x1 SF, F 18x1 SF, F 19x1 SF, F 14x3 SF, F 18x3 SF, F 19x3 SF
- KF 18x1 SF, KF 19x1 SF, KF 18x3 SF, KF 19x3 SF
- KWT 16x1 SF, KWT 16x3 SF

For side-by-side installation of appliances with a stainless-steel front (SF), you also need a **Top-frame**. Please contact Miele to obtain a top-frame in the required width. The width of the Top-frame corresponds to the totale width of you side-by-side combination.

# Side-by-Side Merging Kit KSK 1003



## Side-by-side

### ... without partition

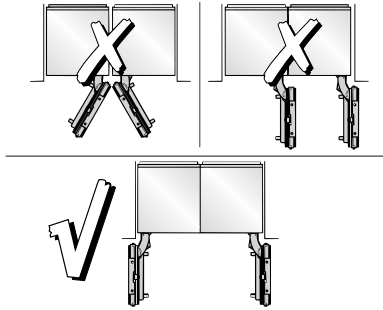

If the appliances are installed directly next to each other (without a partition), they need to be attached together. A heating mat must also be installed. This will help avoid condensation and prevent damages.

### ... with partition

If there is a partition with a thickness **less than 6 5/16" (160 mm)** between the adjacent appliances, then each appliance should be individually installed within its own niche using the mounting accessories included.

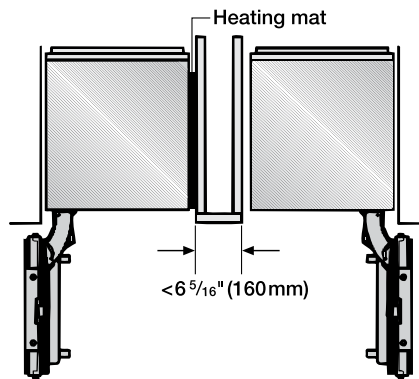

In this case, you will only need the heating mat from the "Merging kit" to avoid condensation and prevent damages.

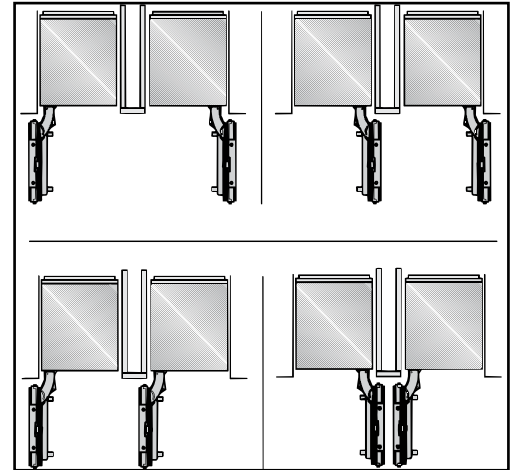

## HEATING MAT TRANSFORMER PLUG DETAILS FOR KSK 1003



### Location Codes

- *KSK 1003- Heating mat connects directly to left-standing appliance*

### Notes

- *Merging kit must be used when combining units*
- *All installations must be done in accordance with local codes*

# Product and Cut-out Dimensions 48" Side-by-Side Combination

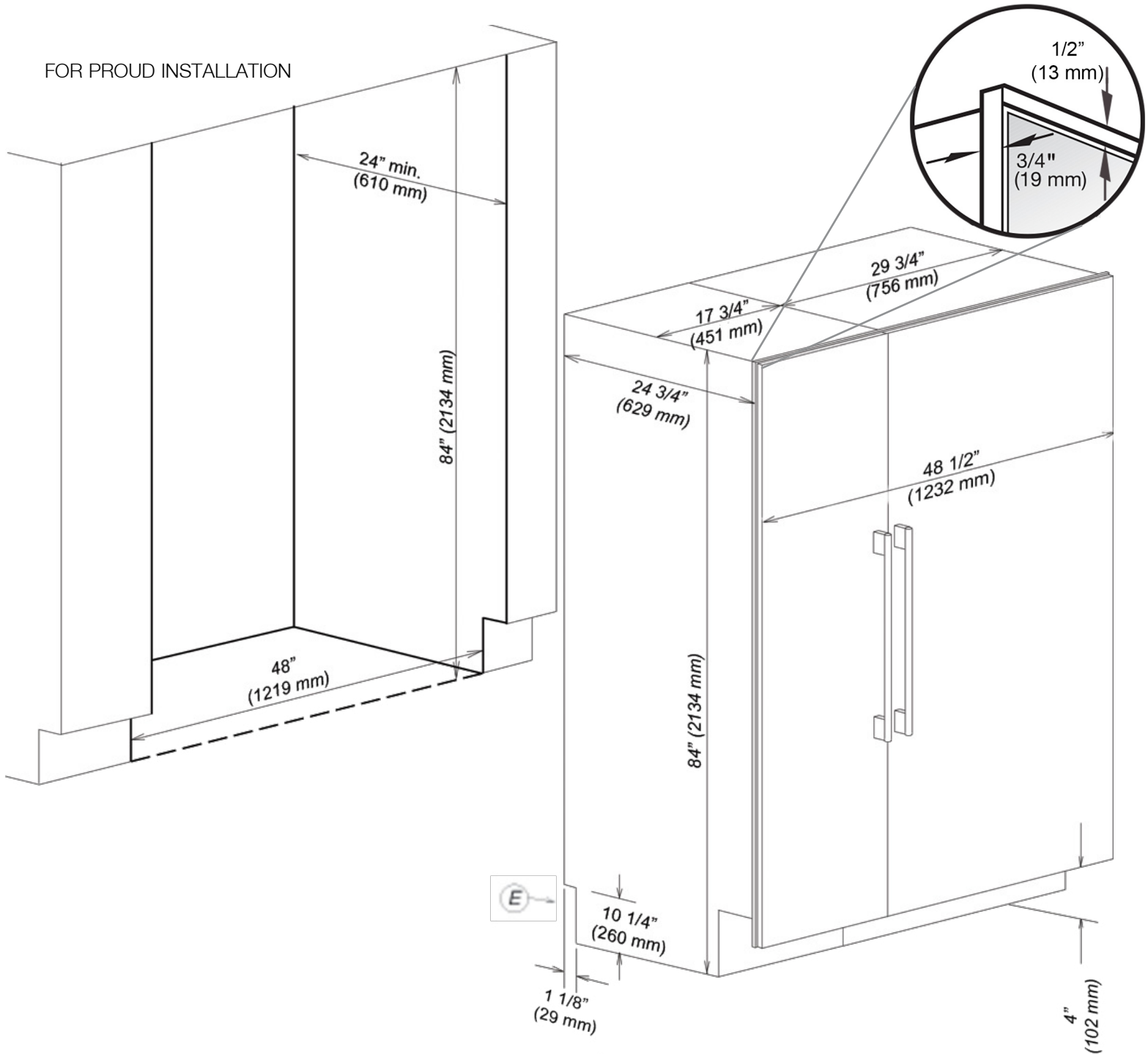

## Location Codes

*E- power cord for refrigeration unit- 5 foot- NEMA 5-15 molded plug power cord connects lower left rear of units*

## Notes

- Merging kit must be used when combining units
- KFT1048SS top frame piece must be used when combining units
- All installations must be done in accordance with local codes
- Sides of adjoining cabinets should be filled (flush to frame) to insure proper fit and finish



# Product and Cut-out Dimensions 48" Side-by-Side Combination

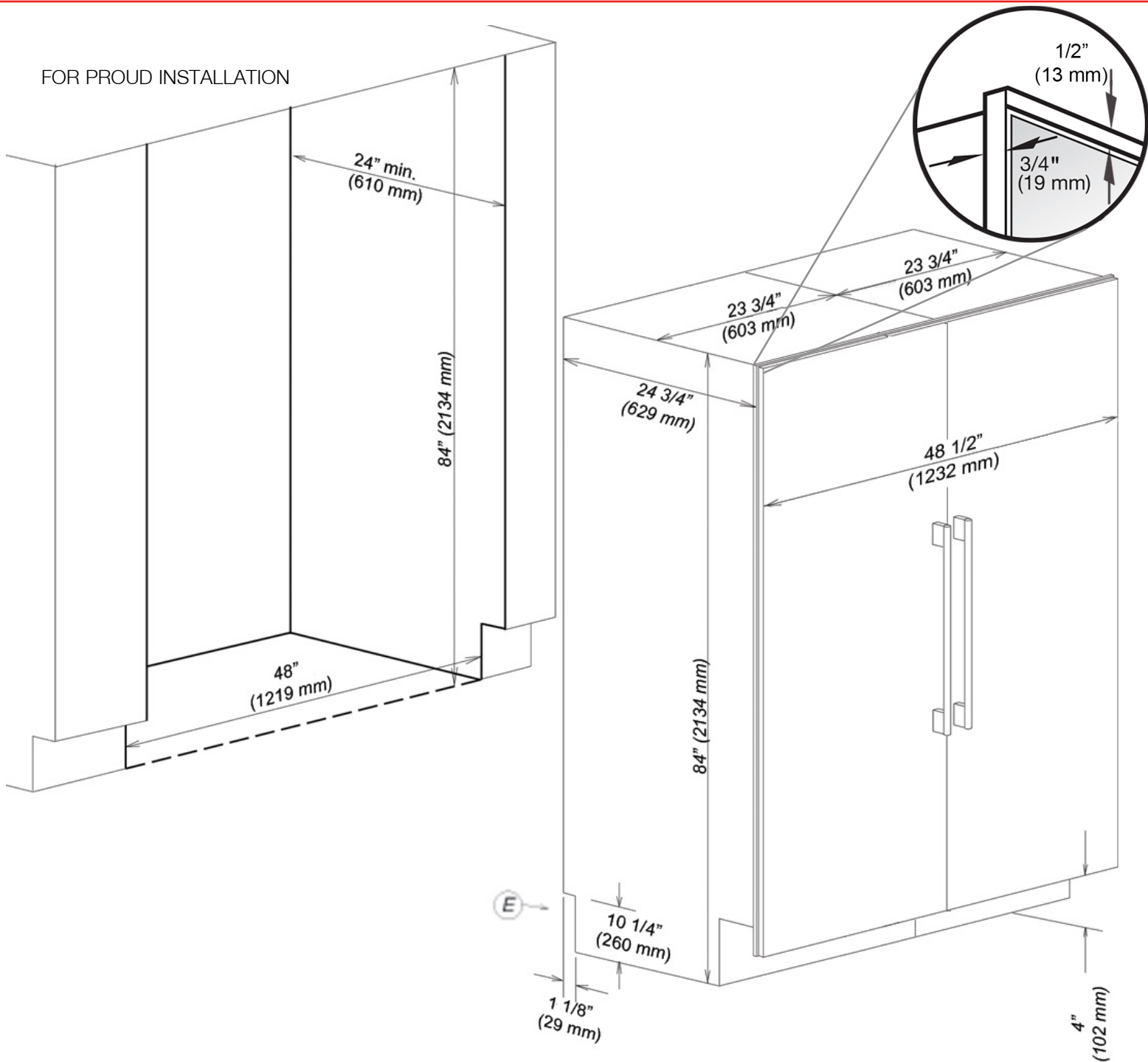

## Location Codes

*E- power cord for refrigeration unit- 5 foot- NEMA 5-15 molded plug power cord connects lower left rear of units*

## Notes

- Merging kit must be used when combining units
- KFT1048SS top frame piece must be used when combining units
- All Installations must be done in accordance with local codes
- Sides of adjoining cabinets should be filled (flush to frame) to insure proper fit and finish

# Product and Cut-out Dimensions 54" Side-by-Side Combination

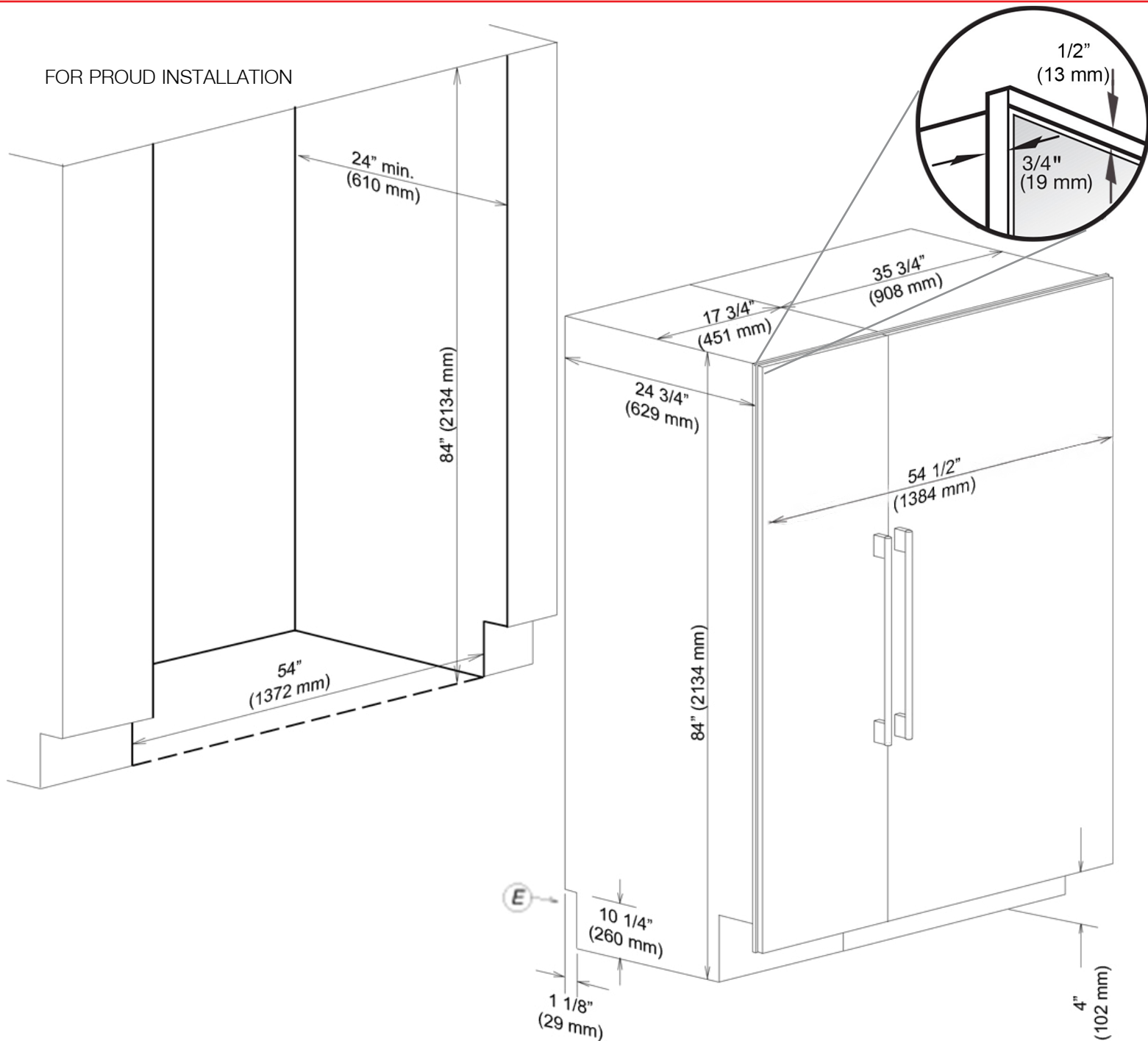

### Location Codes

*E- power cord for refrigeration unit- 5 foot- NEMA 5-15 molded plug power cord connects lower left rear of units*

### Notes

- Merging kit must be used when combining units
- KFT1054SS top frame piece must be used when combining units
- All Installations must be done in accordance with local codes
- Sides of adjoining cabinets should be filled (flush to frame) to insure proper fit and finish

# Product and Cut-out Dimensions 54" Side-by-Side Combination



FOR PROUD INSTALLATION

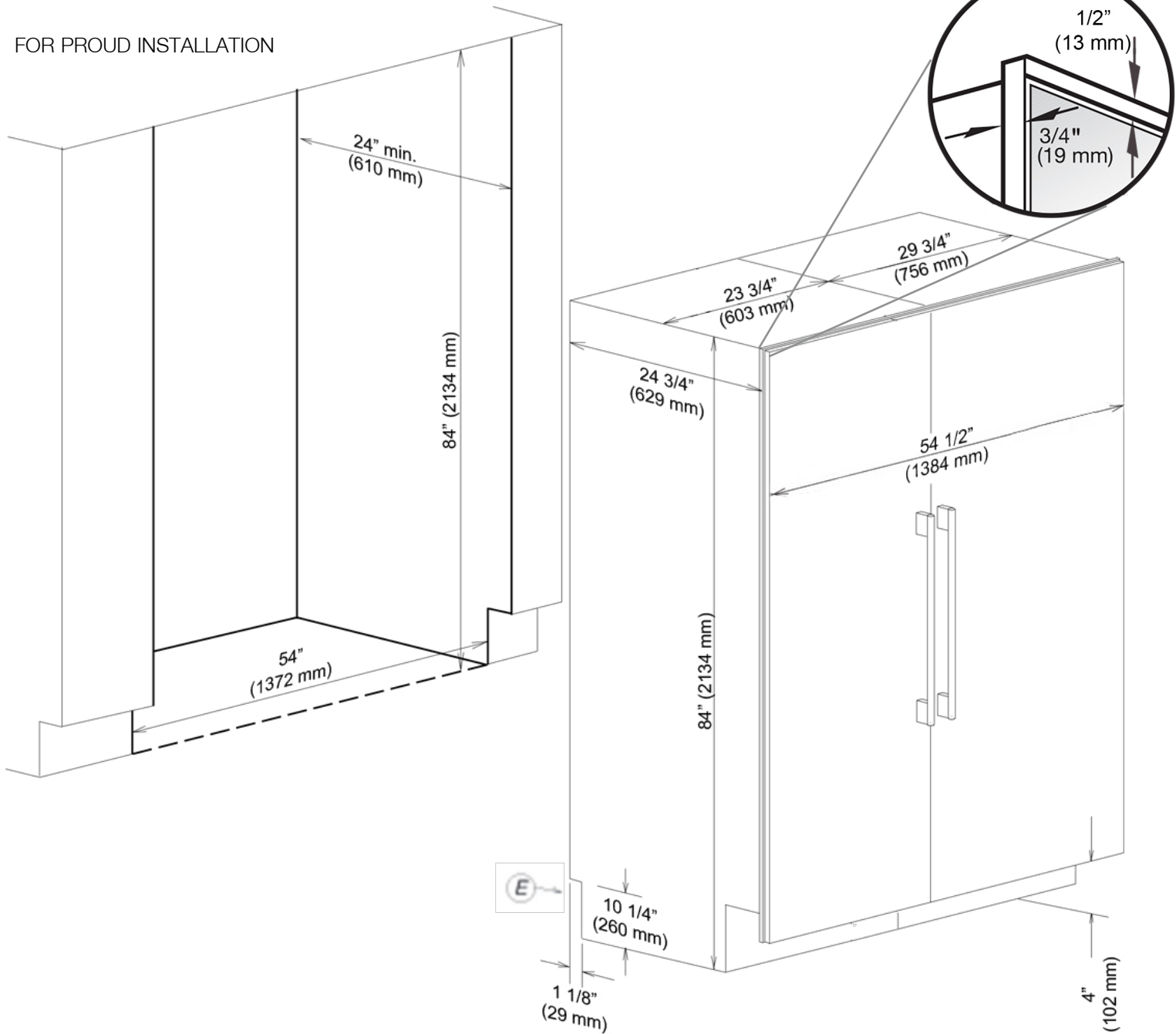

### Location Codes

*E- power cord for refrigeration unit- 5 foot- NEMA 5-15 molded plug power cord connects lower left rear of units*

### Notes

- Merging kit must be used when combining units
- KFT1054SS top frame piece must be used when combining units
- All Installations must be done in accordance with local codes
- Sides of adjoining cabinets should be filled (flush to frame) to insure proper fit and finish

# Product and Cut-out Dimensions 60" Side-by-Side Combination



FOR PROUD INSTALLATION

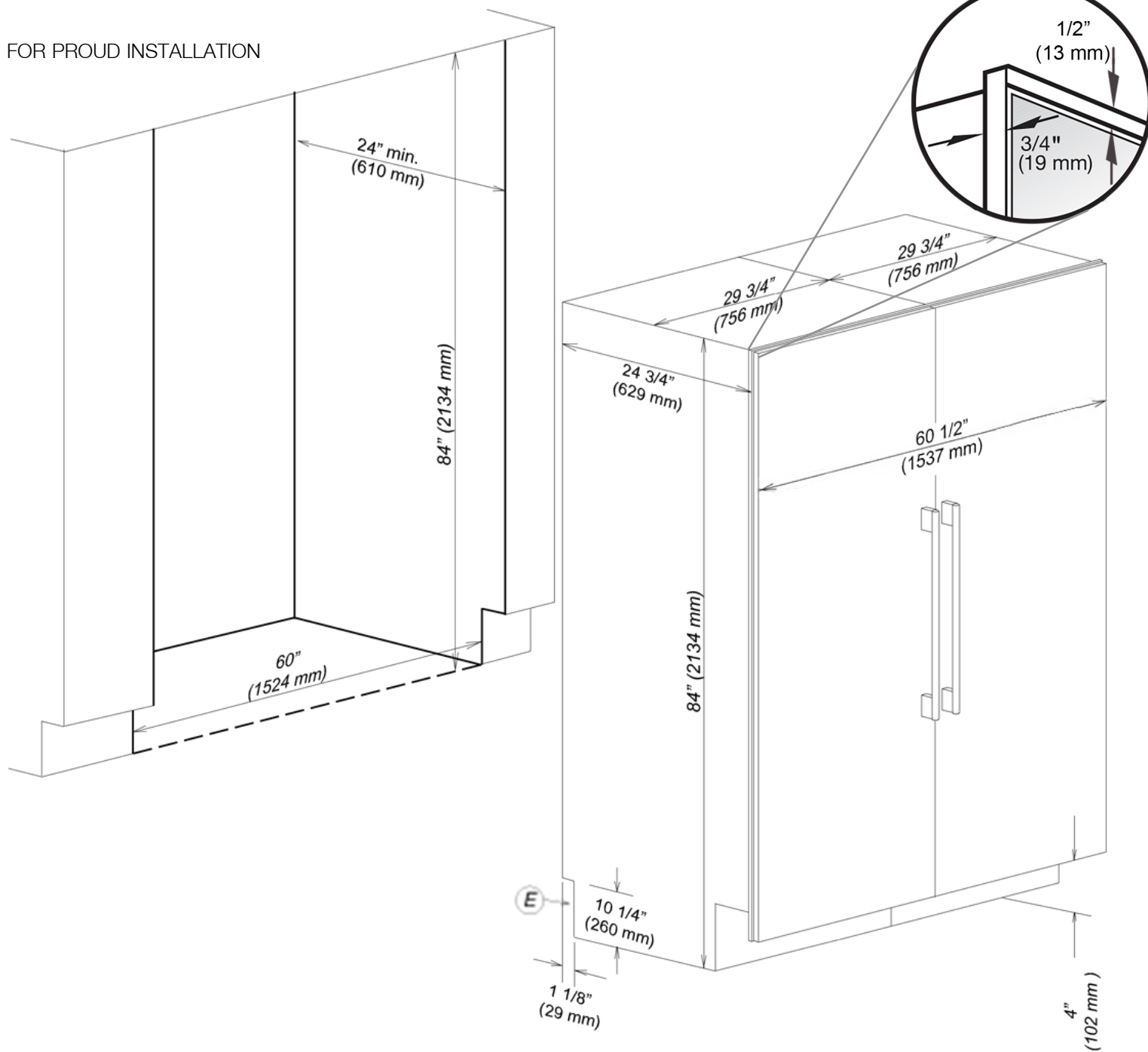

## Location Codes

*E- power cord for refrigeration unit- 5 foot- NEMA 5-15 molded plug power cord connects lower left rear of units*

## Notes

- Merging kit must be used when combining units
- KFT1060SS top frame piece must be used when combining units
- All Installations must be done in accordance with local codes
- Sides of adjoining cabinets should be filled (flush to frame) to insure proper fit and finish



# Product and Cut-out Dimensions 60" Side-by-Side Combination

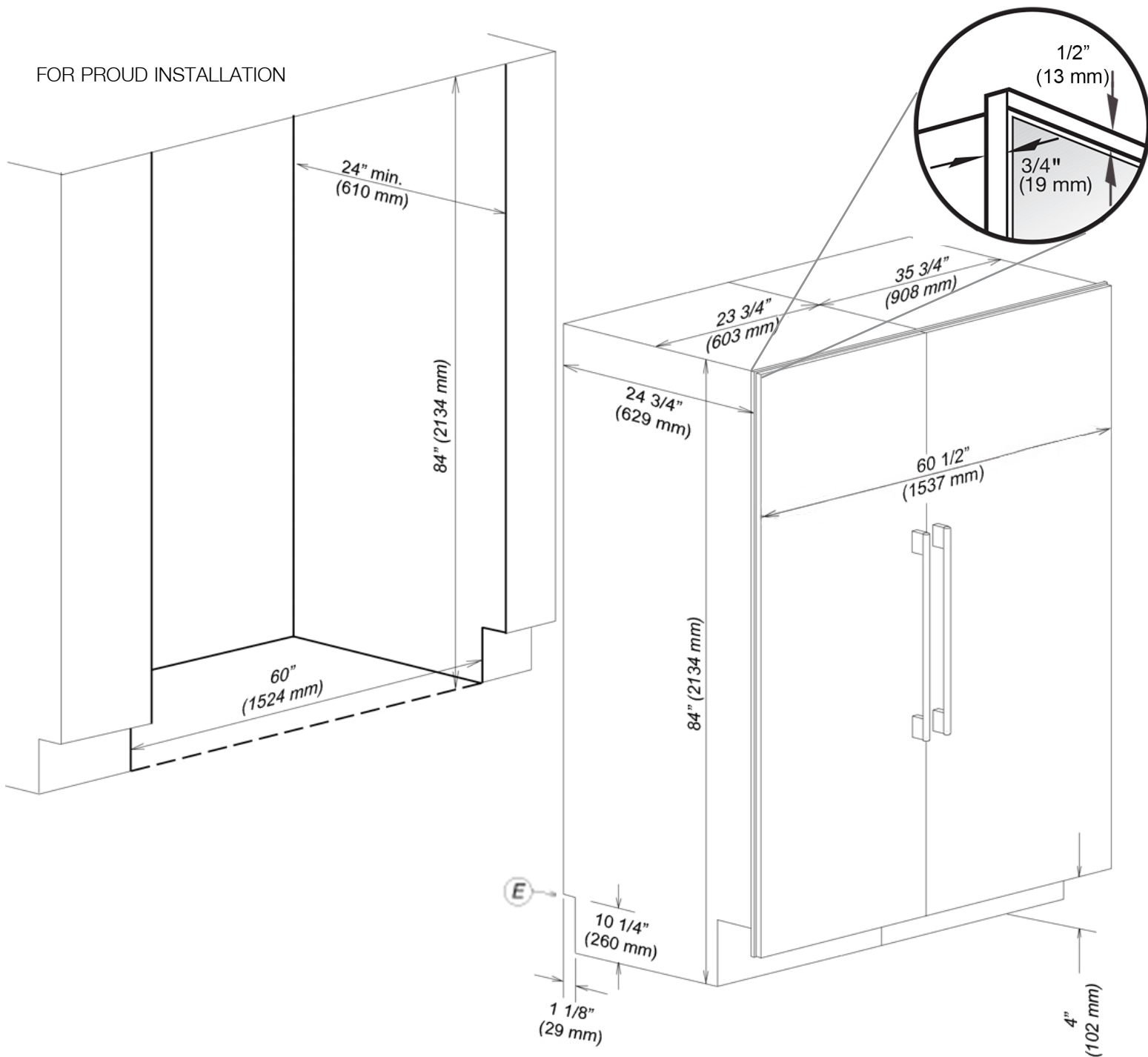

## Location Codes

*E- power cord for refrigeration unit- 5 foot- NEMA 5-15 molded plug power cord connects lower left rear of units*

## Notes

- Merging kit must be used when combining units
- KFT1060SS top frame piece must be used when combining units
- All Installations must be done in accordance with local codes
- Sides of adjoining cabinets should be filled (flush to frame) to insure proper fit and finish

# Product and Cut-out Dimensions 66" Side-by-Side Combination

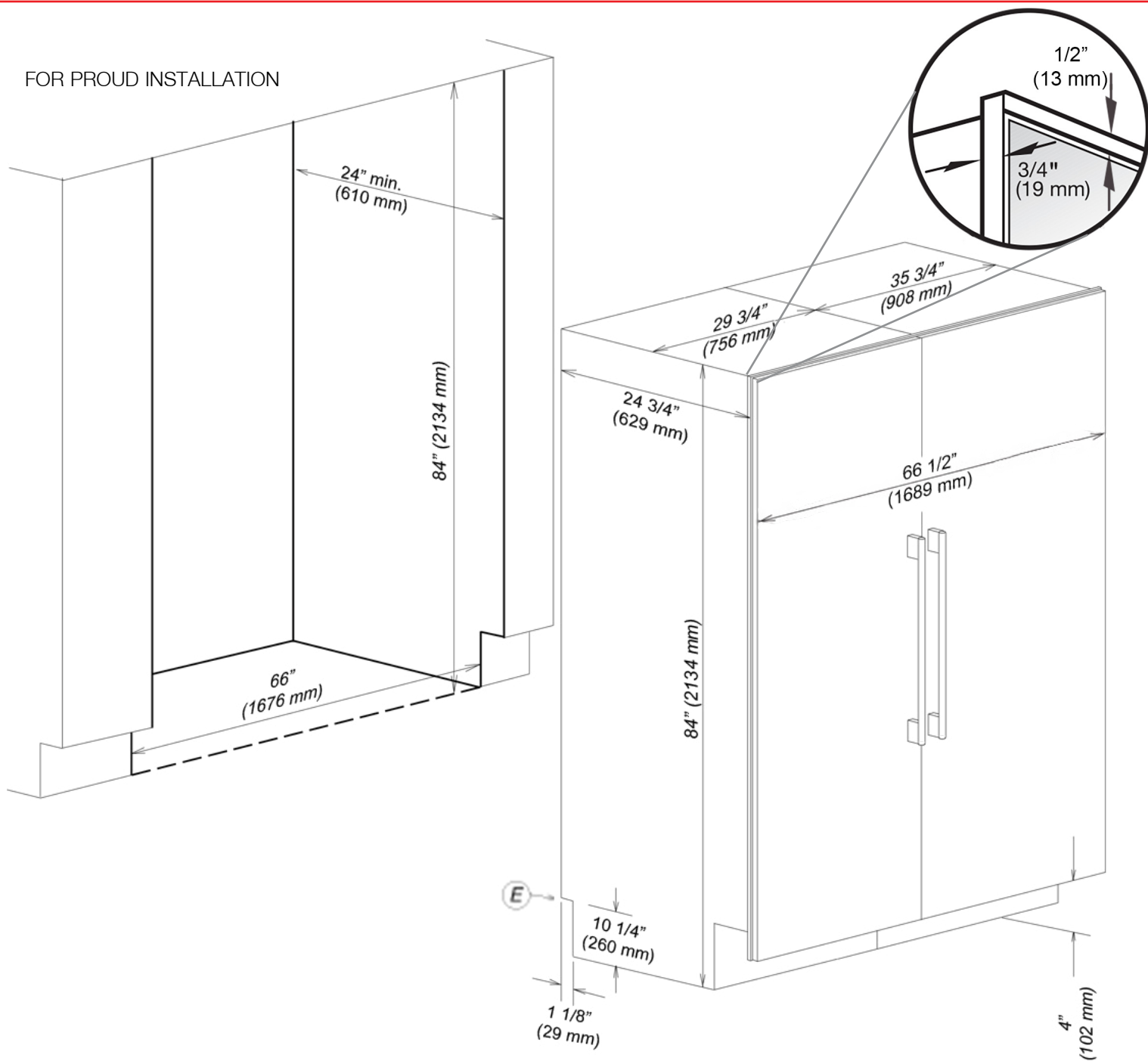

### Location Codes

*E- power cord for refrigeration unit- 5 foot- NEMA 5-15 molded plug power cord connects lower left rear of units*

### Notes

- Merging kit must be used when combining units
- KFT1066SS top frame piece must be used when combining units
- All Installations must be done in accordance with local codes
- Sides of adjoining cabinets should be filled (flush to frame) to insure proper fit and finish

# Product and Cut-out Dimensions 72" Side-by-Side Combination



FOR PROUD INSTALLATION

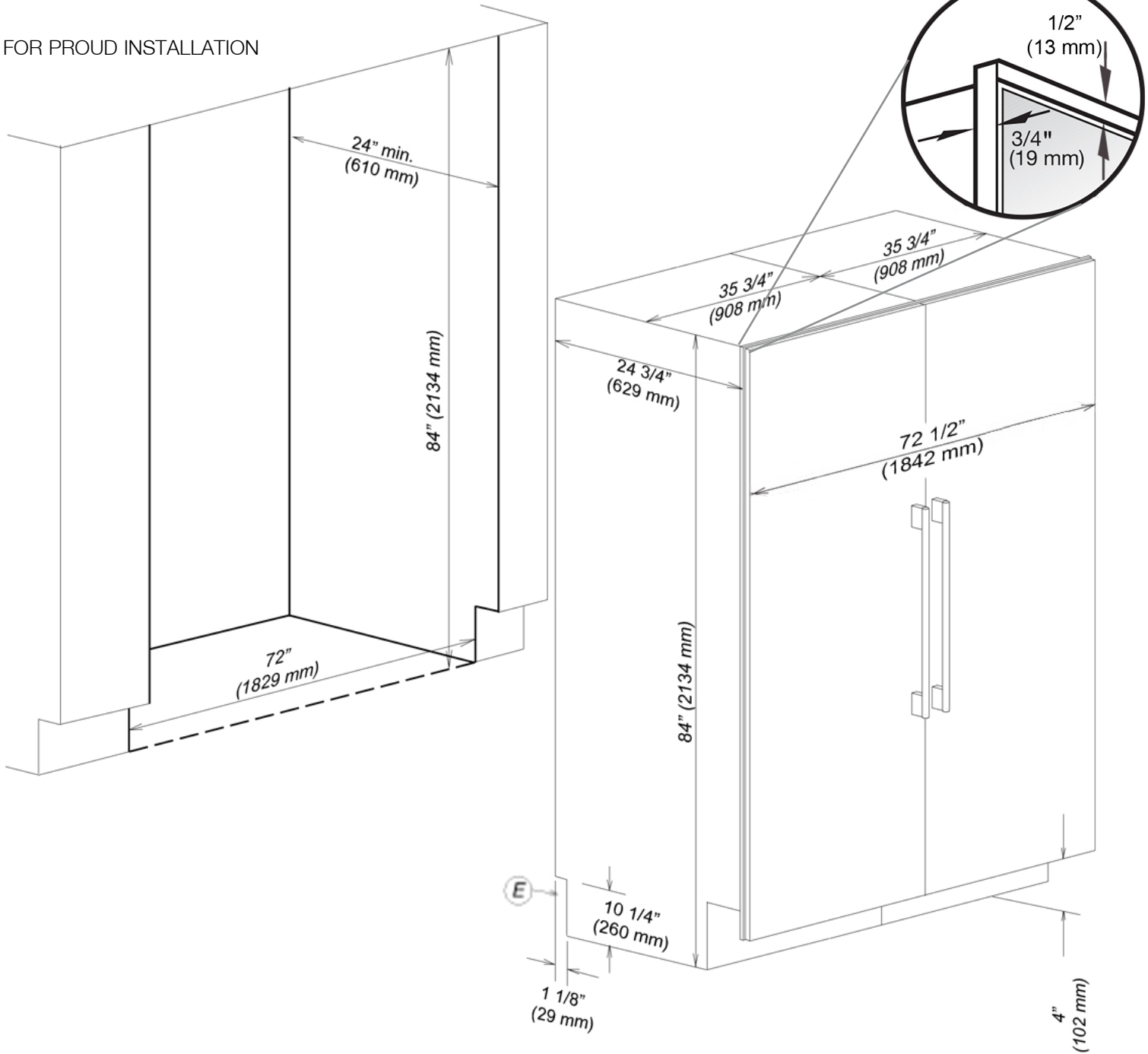

## Location Codes

*E- power cord for refrigeration unit- 5 foot- NEMA 5-15 molded plug power cord connects lower left rear of units*

## Notes

- Merging kit must be used when combining units
- KFT1072SS top frame piece must be used when combining units
- All Installations must be done in accordance with local codes
- Sides of adjoining cabinets should be filled (flush to frame) to insure proper fit and finish