

Incognito Island
Ventilation Hood

DA 6590 D



Incognito Island Ventilation Hood

DA 6590 D



FEATURES

- Designed for vented use
- Front-mounted backlit controls
- Four fan speed; max. 625 CFM
- Removable, dishwasher-safe stainless steel filter
- Glass or stainless steel panels for covering the stainless steel grease filter (**sold separately**); dishwasher-safe for easy clean-up
- Three dishwasher-safe panels
- Filter saturation indicator
- Delayed shutdown for 5 or 15 minutes
- Automatic shutdown of intensive level, programmable for 10 minutes
- Integrated halogen lighting with dimmer
- Polished stainless steel logo
- Stainless steel finish or RAL color options



SPECIFICATIONS

DA 6590 D – Item 28659058USA

Vented	Max 625 CFM setting
Canopy Dimensions	35 ⁷ / ₁₆ " (900 mm) W x 2 ³ / ₄ " (70 mm) H x 23 ⁵ / ₈ " (600 mm) D
Dimensions (Standard Version Height)	42" (1067 mm)
Chimney Dimensions	12" (305 mm) W x 11 ⁵ / ₈ " (298 mm) D
Minimum distance above cooktop	Please refer to page 26 of the installation manual
Color	Available in brushed stainless steel or RAL colors
Electrical	
Electrical Requirements	120 V, 60 Hz, 15 Amps
Power Cord	Hardwired
Electrical Rating	430 W (Blower: 350 W; Lighting: 4x20 W)
Accessories	
Optional Accessory	Reducing Collar (air flow max. 400 CFM)
Shipping	
Shipping Weight	73 lbs (33 kg)
Support	
Call	800.843.7231
20/20	☎2020technologies.com

OPTIONAL PANELS (sold separately)

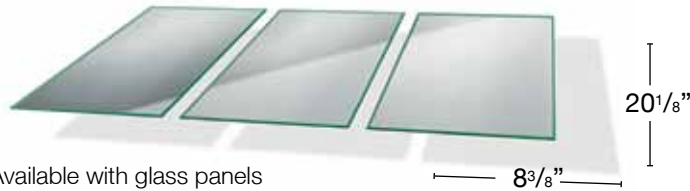

Available with glass panels
DRP 6590 D Glass, Item #09048010



Available with stainless steel panels
DRP 6590 D Stainless Steel,
Item #09048020

Incognito Island Ventilation Hood DA 6590 D



PRODUCT VIEWS

Isometric View

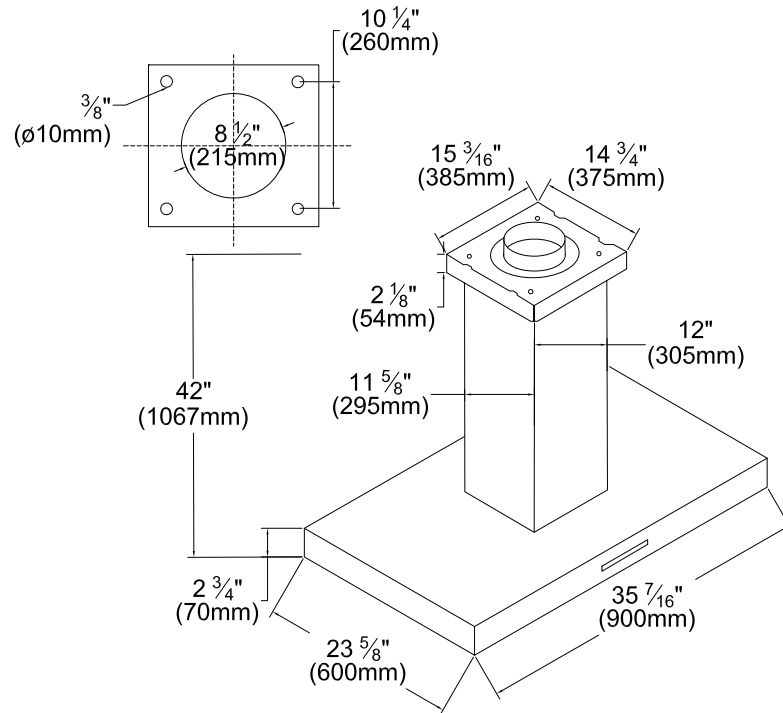

Front View

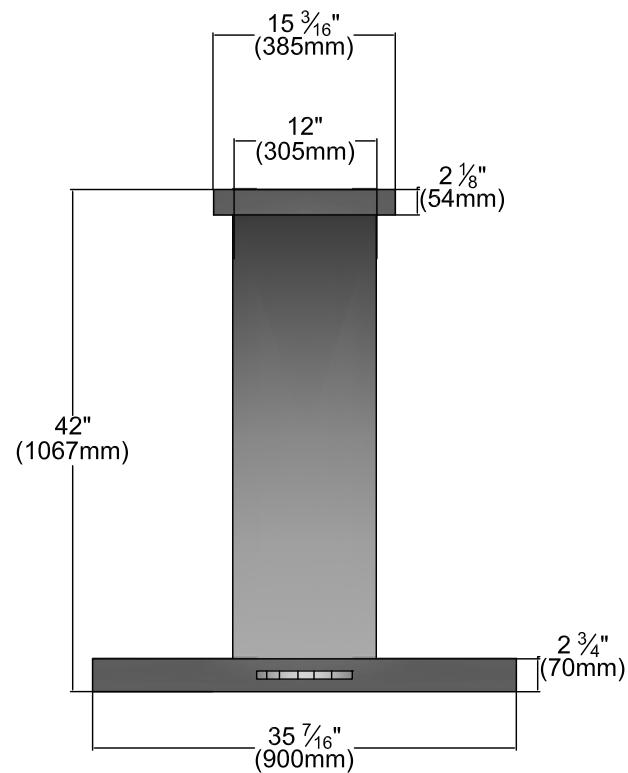

Incognito Island Ventilation Hood DA 6590 D



PRODUCT VIEWS

Top View

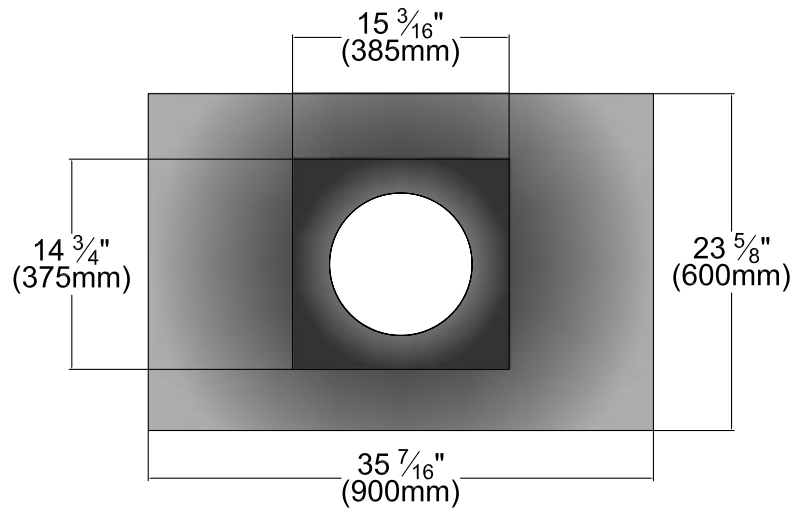

Side View

