

Operating instructions

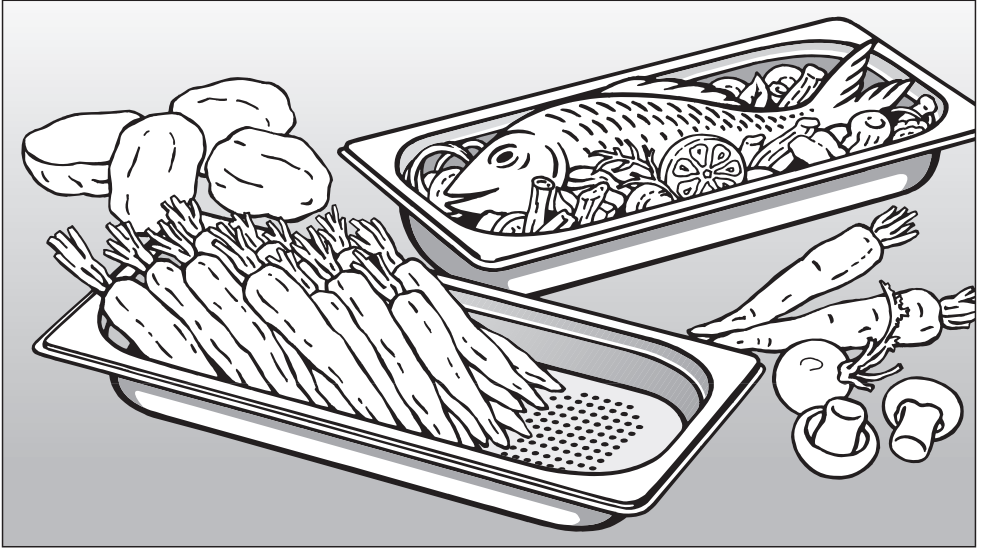

Steam oven

DG 155

DG 155-1

DG 155-2

DG 155-3

To prevent accidents and machine damage, read these instructions

before

installation or use.



Contents

IMPORTANT SAFETY INSTRUCTIONS	4
Guide to the steam oven	8
Control panel	9
Accessories	10
Before using for the first time	13
Setting the water hardness level	13
Setting the altitude	14
Changing the temperature display	16
Operation	18
Before each use	18
Turning the oven on	19
Selecting a program	19
Program table	20
Adjusting the temperature	21
Changing the preset temperature permanently	22
Setting the cooking time	23
Starting the cooking process	24
Changing a program	26
At the end of cooking	27
Insufficient water / water container not in place	28
Overheating protection	29
Safety lock	30
Cooking tips	31
Suitable containers	31
Steaming	32
Defrosting	36
Meal planning	38
Preparing a whole meal	38

Special uses	40
Canning	40
Reheating	41
Blanching	41
Disinfecting baby bottles	42
Cleaning and care	43
Appliance front	43
Drip tray, rack and cooking containers	43
Removable door and drip plate	44
Cooking compartment	45
Runners	45
Connector	46
O-Ring	47
Descaling lock	48
Descaling	49
Frequently asked questions	51
Electrical connection	53
After sales service	54
Data Plate	54
Help protect our environment	55
Disposal of packing materials	55
Disposal of an old appliance	55

IMPORTANT SAFETY INSTRUCTIONS

WARNING- When using your steam oven, follow basic precautions, including the following:

Read all instructions before installation or use of the steam oven to prevent injury and machine damage.

Use the steam oven only for its intended purpose. This appliance is intended for residential cooking only.

This appliance conforms to all uniform safety codes and regulations. The manufacturer cannot be held responsible for damage or injury caused by improper use of this appliance.

Keep these operating instructions in a safe place and pass them on to any future user.

SAVE THESE INSTRUCTIONS

Electrical Safety

Before installation make sure that the voltage and frequency listed on the data plate correspond with the household electrical supply. This data must correspond to prevent injury and machine damage. Consult a qualified electrician if in doubt.

Installation, repair and maintenance work should be by a Miele authorized service technician. Work by unqualified persons could be dangerous and may void the warranty.

Before installation or service, disconnect the power supply to the work area by removing the fuse, "tripping" the circuit breaker, or switching off the power main. Ensure that the power is not restored to the appliance during maintenance or repair work.

Be certain your appliance is properly installed and grounded by a qualified technician. To guarantee the electrical safety of this appliance, continuity must exist between the appliance and an effective grounding system. It is imperative that this basic safety requirement be met. If there is any doubt, have the electrical system of the house checked by a qualified electrician. The manufacturer cannot be held responsible for damage caused by the lack, or inadequacy of, an effective grounding system.

Do not use an extension cord to connect this appliance to electricity. Extension cords do not guarantee the required safety of the appliance, e.g. danger of overheating.

Do not operate any appliance with a damaged cord or plug, or if the appliance has been damaged in any manner. Return the appliance to the nearest authorized service facility for examination, repair or adjustment.

IMPORTANT SAFETY INSTRUCTIONS

Use

■ Inspect the steam oven for shipping damage. Do not install or operate a damaged unit. Contact your Miele Dealer.

■ The steam oven should be installed at a safe height for users to safely access all cooking levels and containers. Otherwise spills could cause burns or scalding and children might be put at risk by the hot appliance door.

■ This equipment is not designed for maritime use or for use in mobile installations such as recreational vehicles or aircraft. However, under certain conditions it may be possible for an installation in these applications. Please contact the nearest Miele dealer or the Miele Technical Service Department with specific requirements.

■ This appliance is intended for domestic use only. It should not be used for commercial purposes.

■ This appliance must only be operated after it has been correctly installed in cabinetry. This is necessary to ensure that all electrical components are shielded.

■ Only use the appliance for its intended purpose. Any other use is at the owner's risk and could be dangerous.

Scalding and Burning hazards

■ When in use, the oven, particularly the inside of the door as well as the outer side by the vent, may become very hot and remain so for a while after the oven has been turned off. Keep children away.

■ Allow the steam oven to cool before putting in or taking out racks.

■ Use pot holders when working with a hot appliance.

■ Avoid hot steam, serious burns and scalds could result.

■ Do not touch hot surfaces, use the handles.

■ When handling cooking containers take care not to let the contents spill.

■ Extreme caution must be used when moving hot liquids.

■ Do not use plastic containers. They may melt at high temperatures in the oven.

IMPORTANT SAFETY INSTRUCTIONS

Children

- To reduce the risk of injury, do not allow children to play in, on, or near the steam oven.
- Do not store items of interest to children in cabinets near the oven. Children climbing on the oven to reach items could be seriously injured.
- Use the safety lock so that children cannot turn the steam oven on or change the settings.
- The door hinges of the appliance could be hazardous. Ensure that children are kept at a safe distance.
- Ensure that any plastic wrap, is disposed of safely and kept out of the reach of children. Danger of suffocation!
- Before discarding an old appliance, disconnect it from the electrical supply, cut off the power cord, and remove any doors to prevent hazards.

Appliance damage

- Do not heat unopened containers of food in the oven. Pressure will build up causing an explosion that will damage the cooking compartment.
- To prevent condensation which could corrode the appliance; do not leave cooked foods in the oven for an extended period of time.
- Do not use items in the steam oven which might rust. This can lead to corrosion of the appliance.
- Do not lean, sit or place heavy items on the open door of the appliance. The door can support a maximum weight of 17 lbs. (8 kg).

IMPORTANT SAFETY INSTRUCTIONS

Appliance maintenance

■ When descaling the oven, only use descaling agents with a citric acid base or the descaling tablets available from Miele. Do not use vinegar. Vinegar will damage the appliance. Follow the manufacturer's safety instructions on the packaging.

■ Wipe out the appliance after each use and leave the door open until the moisture in the cooking compartment has evaporated.

■ If the steam oven is not used for a lengthy period, e.g. vacationing, clean it to avoid odors. See "Before using for the first time - Setting the altitude" and leave the door open until the cooking compartment is dry.

■ Do not use a steam cleaner to clean this appliance. The steam from the cleaning appliance could penetrate live components and permanently damage the oven or cause injury.

Further safety notes

■ In the event of damage or a defect, turn off the appliance immediately. After it has been turned off, isolate it from the main power supply and contact the Miele Technical Service Department. Ensure that the power is not restored to the appliance during maintenance or repair work.

■ While the appliance is under warranty repairs should only be performed by a Miele authorized service technician. Otherwise the warranty will be void.

■ Do not tamper with electrical connections, components or mechanical parts. Never open the outer casing of the appliance.

■ Be sure that cords of other electrical appliances do not come in contact with the steam oven door. The insulation of the cords could become damaged creating a hazard.

■ To protect against electric shock, keep the appliance cord clear of liquids.

■ Do not let the cord hang over the edge of tables or counters, or come in contact with hot surfaces.

■ The use of accessories not recommended by Miele may cause injury.

Guide to the steam oven

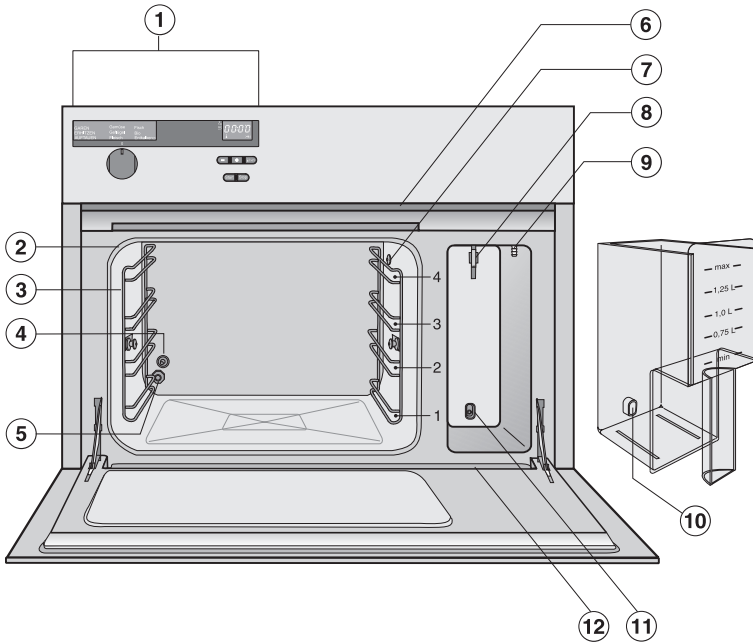

① Control panel

② Door seal

③ Side runners with 4 levels

④ Temperature sensor

⑤ Air Outlet

⑥ Vent

⑦ Steam inlet

⑧ Water container contact

⑨ Feed tube for water return

⑩ Water container connector

⑪ Water Valve

⑫ Drip channel

Control panel

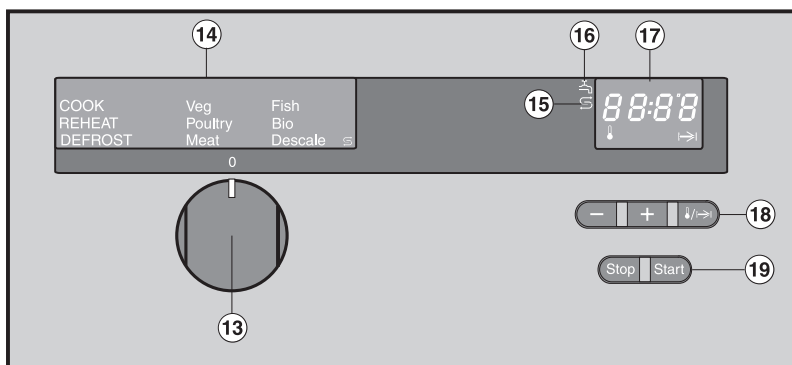



⑬ Program selector

⑭ Program display

⑮ Descale 

⑯ Insufficient water 

⑰ Temperature  and
Timer  display

Buttons with light bars:

⑱ - Decrease

+ Increase

 /  Temperature/Cooking time

⑲ Stop and Start

Accessories

Included

All the accessories can also be reordered if necessary.

Drip tray (3.5 pints, 1.7 l)

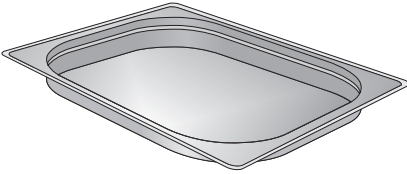

For catching excess liquids

Rack

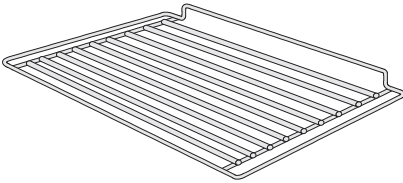

To place cooking containers on

2 cooking containers, perforated (3.2 pints, 1.5 l)

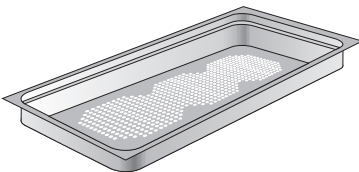

For steaming

Side runners

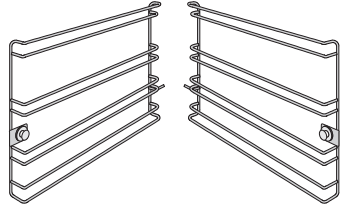

Cookbook



Water container

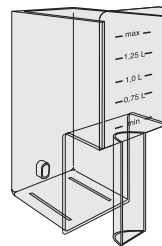

Silicone grease



For lubricating the O-Rings on the connecting valve of the water container. See, "Cleaning and care-O-Ring" for more details.

Connecting valve

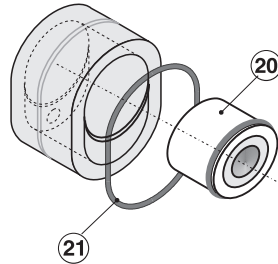

with:

Valve insert, ⑳, white
creates a bridge between the water container, ⑩, and the appliance, ⑪.

O-Ring, ㉑, black

These two parts along with the tool, see "Accessories-optional" can be ordered individually or together as a repair kit.

Accessories

Optional

The following stainless steel cooking containers for steaming can be ordered as optional accessories:

Container	Capacity in pt (l)	Height in inches (cm)
DGG 2 solid	4 (2.0)	2 ³ / ₈ " (6)
DGG 3 solid	6.5 (3.1)	2 ³ / ₈ " (6)
DGGL 4 perforated	6.5 (3.1)	2 ³ / ₈ " (6)

Tool

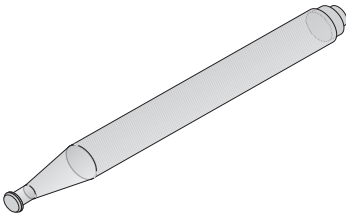

For removing and inserting the valve insert.

This part can be ordered individually or together with the connecting valve parts, see "Accessories-connecting valve," as a repair kit.

Before using for the first time

Setting the water hardness level

For the steam oven to function properly, the water hardness level must be programmed into the unit.

You can use the supplied test strip to check your water hardness level or your local water company can tell you the water hardness of your area.

The steam oven is preset to water hardness level IV (4). If your water is softer than 21 gr/gal the setting should be adjusted.

Please check that the program selector is at "0".

- Press and hold the – button while turning the program selector to DESCALE .

4 1 will appear in the display.

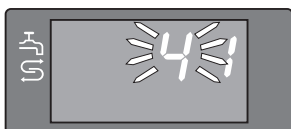

The 1 represents the program number.
The 4 represents the water hardness level.

- Press – or + to select the level III (3), II (2) or I (1) corresponding to your water hardness.

The selected water hardness level will be stored in memory as soon as the program selector is turned to another position.

The water hardness is shown as settings I to IV, equivalent to the following values:

Setting	Display	gr/gal	ppm
I	1	1-7	<20-130
II	2	8-14	140-250
III	3	15-21	270-380
IV	4	>21	>380

Before using for the first time

Setting the altitude

The steam oven must be run through the DESCALING  program before the first use to set the unit for the altitude in your area.

If this is not done, too much steam will be released from the appliance during use.

- Fill the water container with a quart (1 l) of water (do not add descaling agent), place in the appliance and close the door.
- Select DESCALING  using the program selector.

The following will be displayed:



- Press **Start**.

The time will count down from 33 minutes as shown in the display.

Do not turn the program selector during this period or the descaling program will have to be restarted.

A tone will sound when there are 8 minutes remaining and the following will alternate in the display:

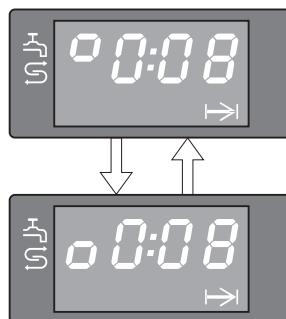

- Empty the water container, refill it with another quart (1 l) of fresh water, and close the door.
- Press **Start**.

The above procedure must be repeated two more times when the tone sounds. Do not be alarmed at the amount of steam emitted.

Before using for the first time

When the time has elapsed you will see the following display:



- Turn the program selector to "0".
- Wait until the oven has pumped the residual water back into the water container, then open the door.

 Hot steam will escape when the door is opened.

- Remove, empty and thoroughly dry the water container.
- Wipe out the oven interior with an absorbent cloth. Remember to wipe down the vent and the drip channel.
- Leave the door open until the moisture in the cooking compartment has evaporated.

Before using for the first time

Changing the temperature display

The display is set to show the temperatures in °F but it can be programmed to show °C.

Please check that the program selector is set to "0".

- Press and hold the - button while turning the program selector to DESCALE .

- Release the - button.

4 7 will appear in the display.

- Press the  repeatedly until *F9* appears in the display.

- Press the - button.

℥9 will appear in the display.

- Turn the program selector to "0".

The conversion is now stored.

If you wish to revert back to °F follow the previous instructions until *℥9* appears in the display.

- Press the + button.



F9 will appear in the display.

- Turn the program selector to "0".

Selecting a temperature

In the cookbook, temperatures are specified in °C, but are shown on the appliance display in °F. Use the following conversion table for setting the temperature on your steam oven.

The temperature on the display can only be shown in 10 °F increments. Therefore, the temperature shown in °F does not always correspond exactly with the temperature specified in °C, i.e. the actual measurable temperature. This discrepancy in temperature is nominal and will not cause a significant difference in cooking time or results.

Temperature in °C	Corresponding Temperature in °F
100	boil
95	205
90	195
85	185
80	175
75	165
70	155
65	145
60	135
55	125
50	115

Operation

Before each use

- Fill the water container.

Only use **tap water**. Never use distilled or mineral water.

The water level must be between the 1.0 l and 1.25 l markings.

Never exceed the "max" level marker.

1 quart (1 l) of water is enough for a cooking time of approximately 20 minutes, 1 $\frac{1}{2}$ quarts (1.25 l) for a cooking time of approximately 60 minutes.

- Insert the drip tray to catch condensed water.

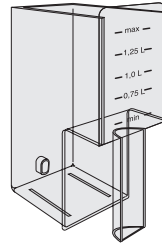

- Push the water container into the appliance until it connects.

Turning the oven on

Do not worry if your appliance makes unusual noises. This will occur when the steam generating unit is being filled or emptied and when the pump is activated.

When the oven is turned on, the fan which extracts steam from the oven will also be heard. The fan will continue running for a while after the oven has been turned off.

To use the oven follow these four steps:

1. Select a program
2. Adjust the temperature if necessary
3. Set the cooking time
4. Press **Start**

The lit bar between the buttons will prompt you to set the next step.

The following pages describe these steps in more detail.

Selecting a program

- Turn the program selector to the desired program, e.g. COOK - Veg.



The preset temperature, e.g. 100 °C (boil) will appear in the display for a short time.

Operation

Program table

Program	Preset temperature in °F (°C)	Temperature range °F (°C)	Suggested use
COOK Universal	212 (100)	175-212 (80-100)	For food which can be cooked at high temperatures, or for boiling
COOK Veg	212 (100)	195-212 (90-100)	For all types of vegetables
COOK Poultry / Meat	212 (100)	195-212 (90-100)	For all types of meat and poultry suitable for steaming
COOK Fish	165 (75)	155-205 (70-95)	For all types of fish
COOK Bio	165 (75)	155-175 (70-80)	For food requiring very gentle cooking
DEFROST	125 (55)	125-140 (50-60)	For defrosting meat, fish, fruit, etc.
REHEAT	205 (95)	175-212 (80-100)	For reheating food
DESCALE	-	-	For descaling

Adjusting the temperature

The preset temperature can be adjusted in 10 °F (5 °C) steps within the range available for that program. See the "Program table" for details.

To change the temperature:

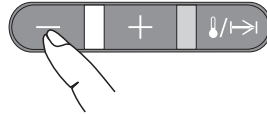

- While the preset temperature is shown in the display, use the + or - button to raise or lower the temperature.

If the display has already changed from preset temperature to cooking time or current temperature you can call up the preset temperature by pressing the thermometer icon button once.

You can adjust the preset temperature at any time.

Operation

Changing the preset temperature permanently

It is possible to permanently change the preset temperature of a program, but only within the range of temperatures available for that particular program (see the table below).

Program	Program number	Preset temp in °F (°C)	Temp range in °F (°C)
Cook Universal	2	212 (100)	175-212 (80-100)
REHEAT	3	205 (95)	175-212 (80-100)
DEFROST	4	130 (55)	115-135 (50-60)
Veg	5	212 (100)	195-212 (90-100)
Fish	6	165 (75)	155-205 (70-95)
Poultry / Meat	7	212 (100)	195-212 (90-100)
Bio	8	165 (75)	155-175 (70-80)

Please check that the program selector is set to "0".

- Press and hold the - button while turning the program selector to DESCAL **S**.

4 7 will appear in the display.

- Press the  button.

1002 will appear in the display.

(2112 will appear if the temperature is set to °F.)

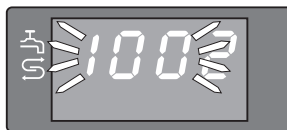

The flashing figures in the first three positions show the temperature, 100 °C in the above example. The figure in the fourth position, number 2 in the example, shows the program number (see table).

- To change the preset temperature for this program press - or +. For example, to set 80 °C (175 °F) for COOK Universal.
- Press the  button to move to the next program and change its temperature as described above.

The new recommended temperature is now stored in memory.

- Turn the program selector to "0" if you do not wish to change any other temperatures.

The next time the changed program is selected the new temperature will appear in the display.

Setting the cooking time

Three zeros and the symbol for cooking time  will appear in the display.

The light bar between the - and + will illuminate.



- Use the + or - button to enter the desired time, (e.g. 20 minutes).



A time of between 1 minute (0:01) and 4 hours 59 minutes (4:59) can be set.

The light bar between the **Stop** and **Start** buttons will illuminate as soon as a cooking time has been set.

The cooking time can be changed as long as it appears in the display, i.e. before the beginning of cooking as well as during cooking. Press the  button to switch between the temperature and cooking time display.

To achieve favorable results using the suggested cook times, do not cook more than 6-8 servings at a time. Regard the recommendations about the cooking containers, see "Cooking tips-Suitable containers".

The cooking time does not depend on the amount of food but on the size of it, e.g. larger potatoes need a longer cooking time than smaller ones.

Operation

Starting the cooking process

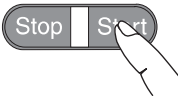

- Press **Start**.

The two light bars will go out and the display will change to show the current temperature of the cooking compartment and the temperature symbol .

Once the steam oven has begun to operate you will hear a pumping noise as water is pumped from the water container into the steam generating unit.



The appliance will then heat up. During this heating time the rise in temperature in the cooking compartment will be shown in the display.

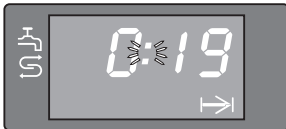

As soon as the set temperature has been reached, the display will change to show the cooking time and the time will begin to count down. This is indicated by the colon flashing between the figures.

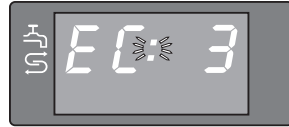

Please note that if the cooking temperature selected is 185 °F (85 °C) or higher and the cooking time is longer than 30 minutes, the steam generating unit will turn off 3 minutes before the end of cooking to make use of residual energy. This is indicated by the letters EC in the display.

Operation

Interrupting a program

You can interrupt a program at any time.

- Press **Stop**.

The colon in the display stops flashing. The light bar between **Stop** and **Start** comes on.

The heat is turned off and the remaining cooking time is stored in memory.

You can now open the door, for example, to stir something.



Hot steam will escape when the door is opened.
Use caution when taking containers out of the oven.

To continue:

- Close the door.
- Press **Start**.

If you have only interrupted the program briefly, you will see the time remaining continue to count down after the door has been closed.

If the program has been interrupted for a longer period, the oven will have cooled and will need to heat up again. In this case, the display will show the current oven temperature rising until it reaches the set temperature. When the set temperature has been reached, the display will switch over to show the remaining cooking time.

Changing a program

To change a program while the oven is in use:

- Press **Stop**.
- Turn the program selector to the new program.
- Enter the new cook time.
- Press **Start**.

At the end of cooking

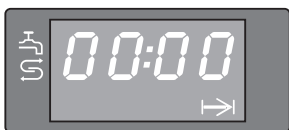

At the end of the set cooking time a tone sounds 5 times and 4 zeros appear in the display.

A tone will sound every minute to remind you to take the food out of the oven.

You can either continue cooking or turn the appliance off.

 Hot steam will escape when the door is opened.
Use caution when taking containers out of the oven.

To continue cooking

- Open the door, but do not turn the program selector to "0".

The tone will stop once the door is opened.

- Select a new cooking time and press **Start** or select a new program, temperature and cooking time then press **Start**.

To turn off

- Turn the program selector to "0".
The tone and all displays will go out.
- Wait until all remaining water is pumped from the steam generator back into the water container before opening the door.

After use



- Remove and empty the water container. Dry thoroughly.
- Wipe the cooking compartment, vent, and drip tray with a soft cloth.
- Leave the door open until cooking compartment is dry.

Operation

Insufficient water / water container not in place

During a program:



If the water container is not seated correctly, there is not enough water in the container, or if it is empty the display will show a small  next to the symbol for insufficient water  and a tone will sound.

- Open the door.
- Check the water level and add more water if needed.
- Push the water container fully into position and close the door.
- Press **Start**.

Cooking will now continue as normal.

After a program has ended: (with the program selector at "0")

If there is water in the steam generating unit and the container is not in place, a tone will sound and **F1** will appear in the display.

- Reposition the water container in the appliance and close the door.
- Press **Start**.

Now the remaining water can be pumped out of the steam generating unit into the water container.

Overheating protection

This appliance has a safety feature which prevents overheating. If the temperature in the steam generating unit becomes too high the oven will shut off automatically.

The oven has shut off if:

- during operation the display only shows the temperature decreasing.
- after starting a new program the oven temperature fails to rise.

To reset the oven

- Turn the program selector to "0" and allow the appliance to cool.
- Restart the program.

If the appliance still does not heat contact the Miele Technical Service Department for assistance.

Operation

Safety lock

The appliance has a safety lock to prevent it from being turned on accidentally by children.

To activate the safety lock:

- Select "DESCALE" .
- Press the - button for at least 5 seconds.

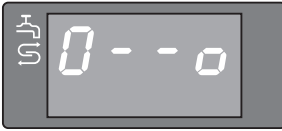



The symbol  for the safety lock will appear in the display.

- Turn the program selector back to "0".

The appliance cannot be used again until the safety lock is deactivated.

To deactivate the safety lock:

- Select "DESCALE" .
- Press the - button for at least 5 seconds until the  symbol goes out.

Suitable containers

Stainless steel cooking containers are supplied with the appliance.

Other containers, are available in a variety of sizes, both perforated and solid, as optional accessories.

- To achieve good results using the suggested cook times, do not cook more than 6-8 servings at a time.
- Use the perforated cooking containers whenever possible, e.g. for cooking vegetables. The steam can reach the food from all sides and cook evenly.
- Place the drip tray at the lowest runner level to collect condensation. Always use the drip tray when using a perforated cooking container.
- Larger and deeper containers can be used for larger items. It is best to space food as much as possible so steam can surround each piece.
- Dense dishes such as casseroles, or food such as peas or asparagus, which have little space between them will take longer to cook because the steam has less space to work in. It is best to use 2 or 3 shallow containers for these foods.

You can also use your own containers and dishes. However, please note the following:

- The container must be heat resistant to 212 °F (100° C). Heat resistant glass, ceramics, porcelain (chinaware), stainless steel or enamel dishes are all suitable.
- Food will take longer to cook in a dish with thick sides.

Ensure that there is a gap of at least 1" (3 cm) between the upper rim of the container and the top of the cooking compartment to allow sufficient steam into the container.

Cooking tips

Steaming

Food	Program	Temperature in °F (°C)	Time in minutes
Vegetables			
Green beans	COOK Veg	212 (100)	3-4
Cauliflower, whole		212 (100)	15-20
Cauliflower, florets		212 (100)	3-4
Broccoli, whole		212 (100)	10-18
Broccoli, florets		212 (100)	7-8
Peas		212 (100)	4-8
Green cabbage, shredded		212 (100)	4-10
Potatoes, unpeeled		212 (100)	15-20
Potatoes, peeled		212 (100)	10-15
Carrots, sliced		212 (100)	3-6
Carrots, whole		212 (100)	8-15
Brussels sprouts		212 (100)	8-15
Celery, sliced		212 (100)	8-10
Spinach		212 (100)	6-8
Asparagus		212 (100)	7-9
White cabbage, chopped		212 (100)	15-25
Savoy cabbage, chopped		212 (100)	10-15
Stuffed peppers	▼	195 (90)	40-50
Tomatoes	Bio	165 (75)	2-5

Note: Temperatures and times in this table are for guidance only.

Food	Program	Temperature in °F (°C)	Time in minutes
Meat and sausage			
Beef stew	Poultry / Meat	212 (100)	80-100
Cutlets in gravy		212 (100)	15-20
Pork ribs		212 (100)	50-70
Sausage		205 (95)	3-5
Veal chops		212 (100)	6-12
Chicken breast		212 (100)	10-20
Chicken thighs	▼	212 (100)	18-22
Fish and seafood			
Cod, fillet	Fish	165 (75)	4-8
Sole, fillet		165 (75)	4-6
Salmon, fillet		165 (75)	8-12
Mussels		205 (95)	10-12
Trout, whole		165 (75)	10-18
Cod steaks		165 (75)	6-10
Mackerel, whole	▼	165 (75)	10-15
Bakes			
Macaroni bake	COOK Universal	212 (100)	50-60
Cheesy rice bake		212 (100)	25-35
Apple bake	▼	212 (100)	30-40
Pate			
Chicken pate	Bio	165 (75)	40-60
Fish pate	▼	165 (75)	60-80

Note: Temperatures and times given in this table are for guidance only.

Cooking tips

Food	Program	Temperature in °F (°C)	Time in minutes
Pasta, rice and grains			
Rice	COOK Universal	212 (100)	20-25
Noodles	I	212 (100)	15-20
Soaking grains	▼	195 (90)	20-40
Legumes			
Beans, presoaked	COOK Universal	212 (100)	30-40
Peas, presoaked	I	212 (100)	15-20
Lentils, not presoaked	▼	212 (100)	25-35
Side dishes			
Potato dumplings, small	Bio	165 (75)	12-18
Potato dumplings, large	I	165 (75)	20-40
Bread dumplings	▼	165 (75)	20-22
Eggs			
Boiled	COOK Universal	212 (100)	4-10
Casserole	▼	212 (100)	12-15
Fruit			
Apples	COOK Universal	212 (100)	3-6
Apple slices	I	212 (100)	2-5
Pear halves	I	212 (100)	3-5
Peaches	I	212 (100)	2-4
Dried fruit	▼	212 (100)	5-7
Desserts			
Creamy desserts, in portions	COOK Universal	195 (90)	30-40
Soufflé, in portions	I	195 (90)	15-20
Steam puddings	▼	195 (90)	12-15

Note: Temperatures and times given in this table are for guidance only.

- You can cook on any level or on multiple levels at a time. The cooking time will not change.
- When cooking frozen food, e.g. vegetables, break up large clumps so that they cook evenly. The cooking time is approximately the same as for fresh vegetables.
- Since steam cooking retains flavors so well, food should not be seasoned until after it has been cooked.
- Fish should be cooked at 165°F (75°C) to maintain its texture and natural color. At this temperature you should cook on only one level.
- To avoid any transfer of tastes caused by moisture dripping from above, solid containers should be used under any perforated containers.
- When cooking with fluids, fill solid containers to the lower rim.
- Food like noodles or rice need to be cooked in fluids. Rice, beans and cereals need to be cooked in equal amounts of food and water.
- Grease the perforated container when cooking fish.
- Grease the solid container when cooking eggs, e.g. scrambled eggs.

Fish can be cooked on more than one level at 195°F (90°C). However, when cooking at this temperature, please note that cooking times will be reduced by several minutes.

Cooking tips

Defrosting

Food to be defrosted	Program	Weight in lb (g)	Temperature in °F (°C)	Defrost time in Minutes	Standing time in Minutes
Meat					
Chopped meat	DEFROST	1/2 lb (250 g)	125 (50)	15-20	10-15
Chopped meat		1 lb (500 g)	125 (50)	20-30	10-15
Chopped meat		2 lb (1000 g)	125 (50)	30-40	10-15
Stew		1/2 lb (250 g)	135 (60)	20-25	10-15
Stew		1 lb (500 g)	135 (60)	30-40	10-15
Stew		2 lb (1000 g)	135 (60)	50-60	10-15
Liver		1/2 lb (250 g)	135 (60)	20-25	10-15
Liver		1 lb (500 g)	135 (60)	25-35	10-15
Liver		2 lb (1000 g)	135 (60)	30-40	10-15
Rabbit		1 lb (500 g)	125 (50)	30-40	10-15
Venison		2 lb (1000 g)	125 (50)	40-50	10-15
Cutlets, sausages		1 3/4 lb (800 g)	135 (60)	25-35	15-20
Poultry					
Chicken		2 lb (1000 g)	135 (60)	40-50	15-20
Chicken legs		1/4 lb (150 g)	135 (60)	20-25	15
Turkey		4 1/2 lb (2000 g)	135 (60)	80-90	15-20
Turkey drumsticks		1 lb (500 g)	135 (60)	40-45	10-15
Turkey drumsticks		2 lb (1000 g)	135 (60)	45-55	10-15
Duck		2 lb (1000 g)	135 (60)	40-50	10-15
Goose		4 1/2 lb (2000 g)	135 (60)	80-90	10-15
Fish					
Fillet		3/4 lb (300 g)	135 (60)	10-15	5-10
Trout		3/4 lb (300 g)	135 (60)	15-20	5-10
Whole fish		2 lb (1000 g)	135 (60)	30-40	10-15
Vegetables					
Frozen in a block, e.g. spinach, green cabbage	 	3/4 lb (300 g)	135 (60)	20-25	10-15
Fruit					
Berries	▼	3/4 lb (300 g)	135 (60)	6-10	10-12

Note: Temperatures and times given in this table are for guidance only.

Defrosting

Frozen food can be defrosted in the steam oven in considerably less time than defrosting at room temperature.

- Remove frozen food from the original packaging and place it in a cooking container or on the rack.
- Select DEFROST.
- If necessary adjust the temperature (see table, "Defrosting").
- Select the defrost time (see table, "Defrosting").
- Press **Start**.

Tips on defrosting

 Be careful when defrosting poultry. Do not use the liquid from defrosted poultry for cooking. Pour liquid down the drain and thoroughly wash the tray, sink and hands.

- Fish does not need to be fully defrosted before cooking. Defrost it so that the surface is sufficiently thawed to take herbs and seasoning. Fish coated with breadcrumbs should be fully defrosted so that the coating sticks.
- Turn, stir or separate food about halfway through the defrosting period.
- Allow food to stand at room temperature after defrosting. This standing time (see table) is necessary to ensure that the food is fully defrosted.
- Do not refreeze food once it has been defrosted.
- Defrost deep frozen, precooked meals according to the manufacturer's instructions.
- Defrost baked items such as pastry or cakes in a closed freezer bag.

Meal planning

Preparing a whole meal

Menu suggestions	Program	Time in minutes
1. Veal chops and sauerkraut, Boiled potatoes	COOK Universal 	23-35 10-15
2. Green cabbage with smoked bacon, Boiled potatoes	 	29-37 10-15
3. Stuffed peppers, Boiled potatoes	 	40-60 10-15
4. Beef stew, Boiled potatoes	 	100-140 10-15
5. Stuffed cauliflower, Potatoes boiled in their skins	 	40-50 20-40
6. Macaroni bake, Stewed apple with raisins	 	75-85 3-5
7. Red mullet in wine & veg. sauce, Boiled potatoes	 	15-20 10-15
8. Fillets of flounder in dill sauce, Rice	 ▼	10-14 20-25
9. Stuffed sole in a creamy sauce, Rice with peas	Fish 	10-12 20-25
10. Blue trout, Parsley potatoes	 	12-18 10-15
11. Fish with oriental vegetables, Rice	 ▼	35-45 20-25

It is both economical and practical to cook a whole meal at the same time in the steam oven. Only a few examples are given above. Consult the cookbook for more information.

Preparing a whole meal

With some planning, an entire meal can be cooked in the steam oven.

- Place cooking containers on different levels or side by side on the rack.

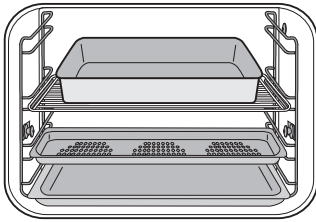

- Insert the drip tray at the lowest level.

In general, cooking times will vary according to the type of food. This means that you will need to open the steam oven at different times to add each dish. Calculate cooking times as follows:

Stuffed peppers 40 minutes
with
Boiled potatoes 10 minutes

(See menu suggestion 3 in the table.)

- First, place the dish with the longest cooking time in the oven.
- To calculate its cooking time, subtract the shorter time from the longer time, i.e. 40 minutes - 10 minutes = 30 minutes in the example given above.

- Press **Start**.
- Set the cooking time for the food that takes longer to cook, e.g. 30 minutes in the above example.
- When the tone sounds, the second dish, the potatoes in this example, should be placed in the oven.
- Set the cooking time for the second dish, e.g. 10 minutes.
- Press **Start** again.

At the end of cooking a tone will sound and both dishes can be removed.

Special uses

Canning

Canning should only be performed by an experienced cook who has received proper training in this method of preserving fruit and vegetables.

Important:

When canning in the steam oven a maximum temperature of 208 °F (98°C) must not be exceeded.

For detailed information on canning see the supplied cookbook.

- Insert the drip tray at the lowest runner and place the rack above it.

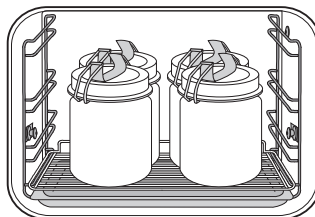

- Put the prepared jars (all the same size) on the rack, ensuring that they do not touch one another.
- Select COOK Universal and set the recommended temperature according to the table.
- Set the time (see table).
- Press **Start**.
- To make use of residual heat, wait 30 minutes after the oven has turned off before removing the jars from the oven.
- Cover jars with a cloth and allow to cool for 24 hours.

Program COOK Universal 		
Produce	Temp in °F (°C)	Time in minutes *
Berries		
Strawberries	175 (80)	45
Red /	175 (80)	50
Black currants	175 (80)	55
Gooseberries	175 (80)	55
Blackberries	175 (80)	55
Fruit with pits		
Apricots	185 (85)	55
Cherries	185 (85)	55
Plums	185 (85)	55
Fruit with stems		
Apples	195 (90)	50
Pears	195 (90)	65
Vegetables		
Beans	195 (90)	120
Peas	195 (90)	120
Carrots	195 (90)	90

* The given times are for 1 quart (1 l) glasses.
 1 pint (0.5 l) glasses = times reduced by 15 min.
 1 cup (0.25 l) glasses = times reduced by 20 min.

Reheating

The steam oven can be used to reheat dishes.

- Place the food on a flat plate and cover it with a deeper plate or aluminum foil.
- Select REHEAT.
- Select a time of between 5-8 minutes, depending on the type of food.
- Press **Start**.

Blanching

The steam oven can also be used to blanch vegetables to prepare them for freezing.

- Put the prepared vegetables (cleaned, washed, chopped etc.) into a perforated cooking container.
- Place the container on the rack in the oven and insert the drip tray at the lowest level.
- Blanch using COOK Universal at a temperature of 195 °F (90 °C).
- Set a time of 1-2 minutes.
- Press **Start**.
- Once blanched, plunge the vegetables into cold water to cool quickly. You can then freeze them when they have dried thoroughly.

Special uses

Disinfecting baby bottles

The steam oven can be used to disinfect baby bottles and other containers. Check beforehand that all parts are heat resistant to 212 °F (100 °C).

- Place the drip tray on the lowest runner level and place the rack above it.
- Dismantle, clean and thoroughly rinse the bottles. Space the individual parts out on the rack, ensuring that they do not touch one another. This allows the hot steam to reach all sides.
- Select COOK Universal. The recommended temperature of 212 °F (100 °C) is suitable for disinfection.
- Set a time of 15 minutes.
- Allow to dry naturally and use as soon as possible after disinfection. All parts of the bottles must be completely dry before they are reassembled.

Let the appliance cool before cleaning. Clean and dry the steam oven after each use. Close the door only after the cooking compartment is completely dry.

Never use a steam cleaner to clean the appliance. Pressurized steam could damage electrical components and cause a short circuit.

Never use cleaners containing sand, silica, soda, chlorides or scouring agents. Hard brushes, scouring cloths, steel wool and other abrasive materials should not be used.

Appliance front

The front of the appliance and the control area can be cleaned with a sponge and a solution of warm water and non abrasive liquid detergent. Dry with a soft cloth.

Stainless steel

Stainless steel surfaces can be cleaned using a non-abrasive stainless steel cleaner.

To help prevent soiling, a conditioner for stainless steel can also be used. Apply sparingly with even pressure.

Stainless steel colored controls

Clean the buttons and knobs with a sponge and a solution of warm water and liquid soap.

These controls may become discolored or damaged if not cleaned regularly. Do not use a stainless steel cleaner on the knobs or buttons.

Drip tray, rack and cooking containers

The drip tray, rack and cooking containers should be washed and dried each time they are used.

They can be washed in the dishwasher.

Cleaning and care

Removable door and drip plate

Removing the door will make it easier to reach into the oven interior to remove the drip plate, ⑳.

- Open the door fully.

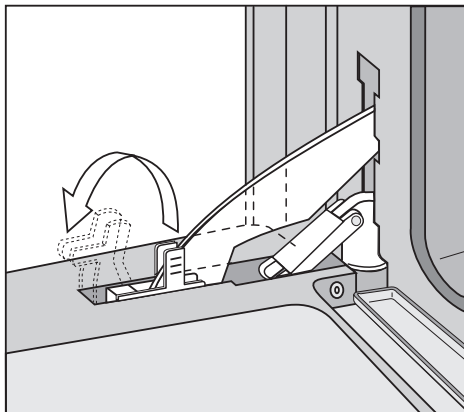

- Flip up the clamps at the front of the door hinges.
- Slowly close the door until the clamps are touching the frame of the oven interior.

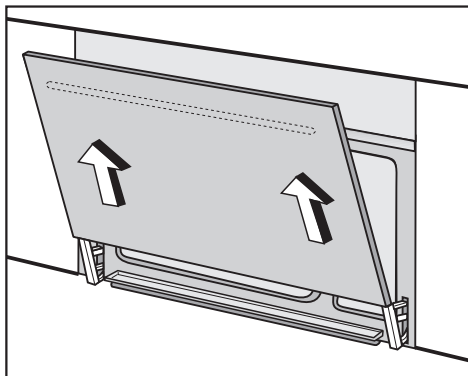

- While holding the door with both hands, lift the door until the hinges disengage. Remove the door.

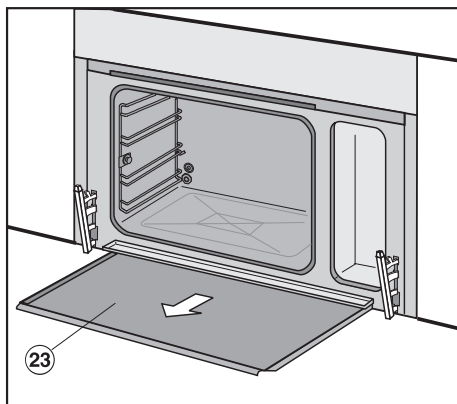

- If necessary the drip plate, ㉓, can be removed for cleaning. After cleaning, dry it and slide back into the oven with the cut-out to the rear.

To refit the door:

- Place the door on the hinges and slide down.
- Open the door fully and push the clamps back down.
- Close the door.

Cooking compartment

The cooking compartment including the door seal and the steam oven door should be cleaned after each use. Allow the oven to cool before cleaning.

Most cooking residues can be easily removed using a sponge, liquid detergent and warm water.

Wipe the interior with clean water and dry with a soft cloth.

Runners

The side runners can be removed before cleaning the cooking compartment.

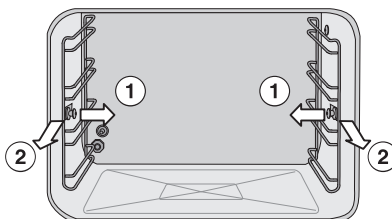

- Pull on the knobs to release the runners, ①. Then pull each runner out of the oven, ②.

The runners can be cleaned with water and liquid detergent or in a dishwasher.

To refit the runners, reverse the above steps. Insert them into the rear of the oven and push in at the sides.

Cleaning and care

Connector

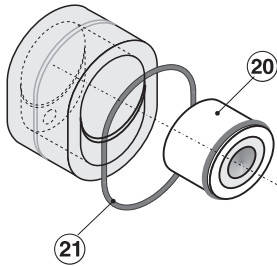

The connector on the water container consists of a valve insert, (20), and an O-Ring, (21). There is also a connector on the appliance itself, this however only consists of the valve insert, (20).

The valve insert and/or the O-ring may need replacing if:

- an unusually large amount of water collects in the bottom of the appliance where the water container connects to the valve.



- a tone sounds and the symbol for insufficient water is lit, even though the water container is full and placed correctly.

To replace the valve insert (20)

- Insert the pointed end of the tool (see "Accessories") into the valve insert and pull the valve out.

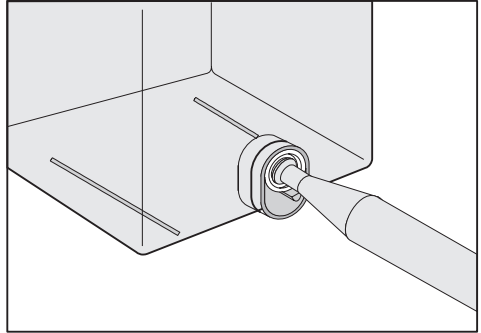

From the water container, and

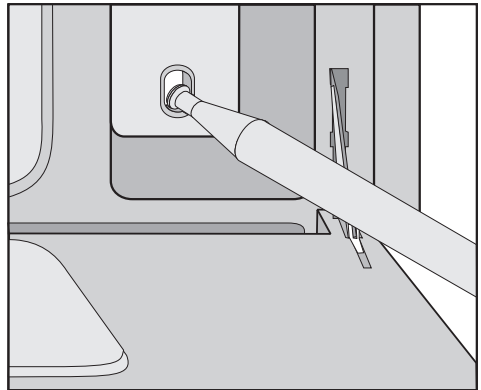

from the appliance.

- Attach a new valve insert, (20), to the blunt end of the special tool.
- Insert this into the opening of the connector.

Make sure that the sealing ring on the valve insert is at the front.

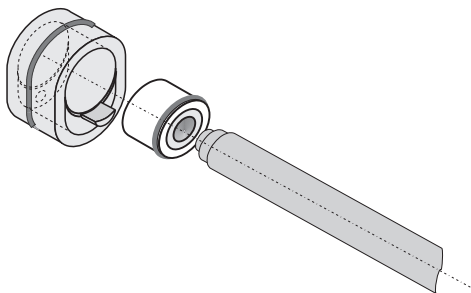

- Press the valve insert firmly into position using the blunt end of the tool.

O-Ring

Over time the water container may become difficult to insert and remove from the appliance.

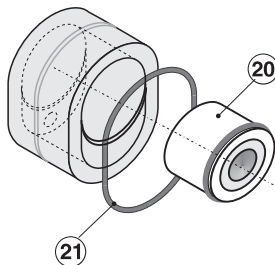

If this happens the black O-Ring, (21), should be lubricated with a very small amount of the silicone grease supplied. Leave the O-Ring on the connector while doing so.

Take care when using silicone grease.

- Remove any silicone grease from your skin by washing with soap and water.
- If silicone gets into the eyes flush with plenty of clean water.
- If silicone is swallowed seek medical attention.

When lubricating the O-Ring only use the silicone grease supplied. Never use margarine, oil, or any other grease or fat on the O-Ring because they will cause deterioration.

Cleaning and care

To change the O-Ring ② on the water container:

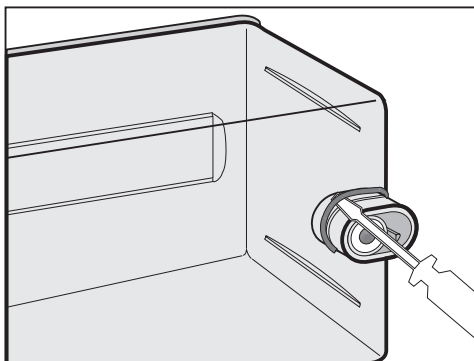

- Lay the water container on its side.
- Use a knife or small screwdriver to get underneath the O-Ring.
- Pull the old O-Ring off.
- Slide the new O-Ring on to the connector. Then lubricate it with the silicone grease supplied.

Descaling lock



If 5 appears for a short time in the display after selecting a program the appliance needs to be descaled.

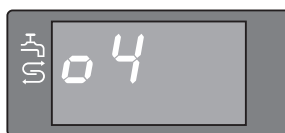

The display indicates that the appliance can be used 5 more times before it will lock. If the appliance is not descaled immediately a 4 will appear in the display the next time the appliance is used, and so on.





If the display shows a 0, the appliance is locked and a tone will sound.

The machine cannot be used until the descaling program has been run.

Descaling

Only use citric acid agents for descaling. Do not use vinegar or descaling agents containing vinegar or acetic acid; they will damage the appliance.

- Use a household descaling agent containing citric acid diluted with water to make 1 quart (1 l) of solution, or contact Miele to order descaling tablets. Follow the manufacturer's instructions.
- Place the solution in the water container and push it into the machine until it engages.
- Turn the program selector to DESCALE .

A small  will appear in the display next to the symbol for descaling  and a program time of 33 minutes will also appear. At the same time the light bar between the **Stop** and **Start** buttons will illuminate.



- Press **Start**.

The descaling program can only be canceled during the **1st minute** after pressing the **Start** button. A new program cannot be selected until the descaling program has been completed.

Do not turn the program selector during the descaling process. If it is turned before the end of the program the entire process will have to be restarted.

Cleaning and care

When 8 minutes show in the display a tone will sound and the following will alternate in the display:

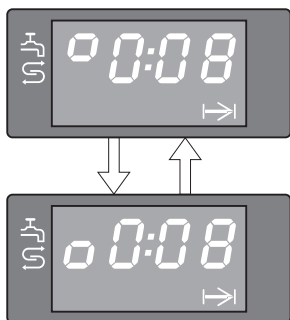

- Empty the water container and refill with 1 quart (1 l) of **fresh tap water**, reposition it in the appliance and shut the door.
- Press **Start**.

This procedure must be repeated two more times when the tone sounds. Do not be surprised at the amount of steam that is emitted.

At the end of the process the following will appear in the display:

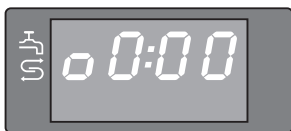

- Turn the program selector to "0".
- Wait until the appliance has pumped any remaining water back into the water container before opening the door.

Be careful of hot steam when opening the door.

- Take the water container out of the appliance, empty and dry with a soft cloth.
- Wipe out the oven interior with an absorbent cloth. Remember to wipe down the vent and the drip channel.
- Leave the door open until the moisture in the cooking compartment has evaporated and the interior is dry.

If there is a **power failure** during the descaling process, 33 minutes will show in the display once power has been restored. The light bars between the Stop and Start buttons will come on.

- To continue the process press the **Start** button.

If the **program selector is moved during a power failure**, the display will remain dark after power has been restored and the light bar between the Stop and Start buttons will flash.

- Turn the selector back to the **DESCALE**  position and press the **Start** button.

Maintenance and repair work should be by a Miele authorized service technician. Work by unqualified persons could be dangerous and may void the warranty.

What to do if ...

... the fan can still be heard after the appliance has been turned off?

The appliance has a fan which removes steam from the oven.

The fan will continue to run for a while after the oven has been turned off.

... the appliance does not heat?

Check whether:

- the **Start** button has been pressed.
- the safety lock has been activated.
- the Overheating Protection has been triggered (see, "Overheating Protection").
- the circuit breaker has tripped.
- the fuse has blown.

If one of these is not the cause then disconnect the appliance from the power supply for about 1 minute, by switching off the power main or tripping the circuit breaker.

Reconnect the power and turn the appliance on. If it still does not heat, contact the Miele Technical Service Department.

... a great deal of steam comes out of the appliance while it is in use?

It is possible that the appliance was not thoroughly rinsed during the "Descaling" program before it was used for the first time.

Refer to "Setting the altitude" and carry out the procedure as described.

If this does not solve the problem, call the Miele Technical Service Department.

... steam escapes out of a closed appliance door or any other part of the steam oven?

Check whether the door seal:

- is seated correctly. If necessary, press it in all the way around the door to make sure it is seated.
- shows any signs of wear and tear, (e.g. cracks). If so it must be replaced. Call the Miele Technical Service Department.



Frequently asked questions

... the following symbols and figures appear in the display and a tone sounds:

 : Insufficient water

Check whether:

- the water container has been pushed in as far as it will go.
- there is sufficient water in the water container.
- any parts of the connector are deteriorated or broken and need replacing.
See "Connector" section for details.

  : The appliance has locked and requires descaling (see "Descaling").

... the oven cavity temperature and the temperature symbol are flashing in the display:

There was a power failure during a program. Press **Start**.

... after turning the appliance off (program selector at the "0" position) a continual tone is heard and F1 appears in the display?

Check whether the water container is in the appliance to accept residual water being pumped back out of the oven.

All electrical work should be by a licensed electrician, in strict accordance with national and local safety regulations and standards.

- **Note to installer:**
Please leave these instructions with the consumer.
- **Power supply:**
Please check the data plate for verification of:
240 VAC, 60 Hz, 15A,
L1, L2, Ground.

Caution:
Disconnect the main power supply before servicing. To reduce the risk of electric shock, make sure that the appliance is properly grounded after installation.

WARNING : THIS APPLIANCE MUST BE GROUNDED

For USA only

The appliance is provided with 3 terminal leads, 1 black wire (L1), 1 red wire (L 2) and 1 green wire (GND) which have to be connected to a dedicated junction box. Connect the black wire to L1, the red wire to L2 and the green wire to GND.

ALSO SEE THE WIRING DIAGRAM PROVIDED WITH THE APPLIANCE.

For CDN only

The appliance is provided with 3 terminal leads, 1 black wire (L1), 1 red wire (L 2) and 1 green wire (GND) which have to be connected to a dedicated junction box. Connect the black wire to L1, the red wire to L2 and the green wire to GND.

All hot wires (black and red) have to be fused individually before connecting them to the main power supply leads.

Use 15 Amp fuses or circuit breakers for appliances rated 240 VAC.

ALSO SEE THE WIRING DIAGRAM PROVIDED WITH THE APPLIANCE.

After sales service

In the event of a fault which you cannot correct yourself please contact the Miele Technical Service Department

USA 1-800-999-1360
techserv@mieleusa.com

CDN 1-800-565-6435
service@miele.ca

When contacting the Technical Service Department, please quote the model and serial number of your appliance. These are shown on the data plate.

Data Plate

Please attach the data plate in the space provided below.



Disposal of packing materials

The cardboard box and packing materials are biodegradable and recyclable. Please recycle.

Ensure that any plastic wrap, is disposed of safely and kept out of the reach of children. Danger of suffocation!

Disposal of an old appliance

Old appliances contain materials that can be recycled. Please contact your local recycling center about the possibility of recycling these materials.
Disposal of an old appliance

Before discarding an old appliance, disconnect it from the electricity supply, cut off the power cord and remove any doors to prevent hazards.

When contacting the Technical Service,
please quote the model and serial number
of your appliance.

The Miele logo is displayed in a bold, white, serif font against a solid black rectangular background.

Miele, Inc. (USA)

National Headquarters

9 Independence Way
Princeton, NJ 08540
Phone: 800-843-7231
609-419-9898
Fax: 609-419-4298
www.mieleusa.com

**Technical Service & Support
Nationwide**

Phone: 800-999-1360
Fax: 888-586-8056

Miele Limited (CDN)

National Headquarters

55G East Beaver Creek Road
Richmond Hill, ON L4B 1E5
Phone: 800-643-5381
905-707-1171
Fax: 905-707-0177
www.miele.ca
info@miele.ca (general enquiries)
professional@miele.ca (commercial enquiries)

Mielecare National Service

Phone: 800-565-6435
905-850-7456
Fax: 905-850-6651
service@miele.ca (Tech. Service)