

Operating and Installation Instructions

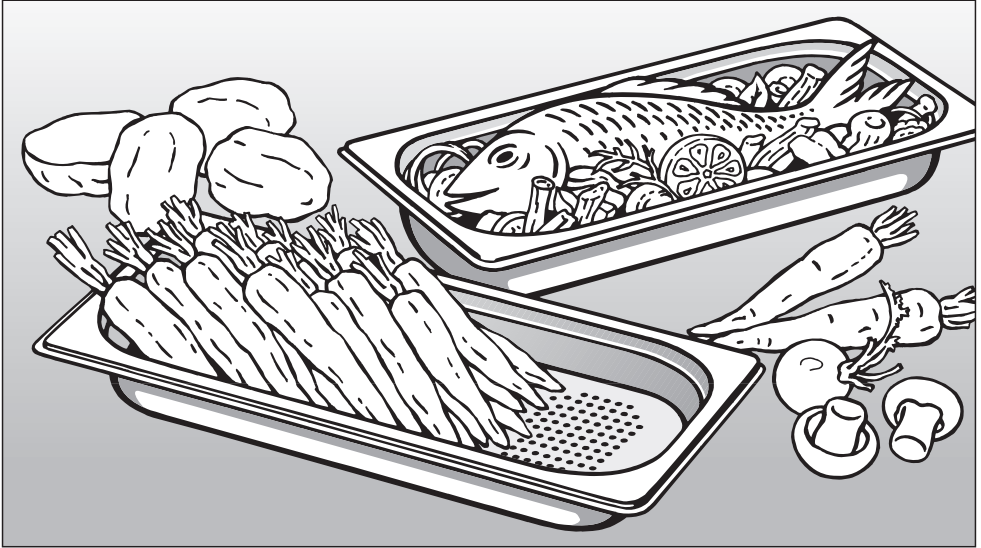

Steam oven DG 4080

To prevent accidents
and appliance damage
read these instructions

before

installation or use.

en - US, CA

M.-Nr. 06 546 610

Contents

IMPORTANT SAFETY INSTRUCTIONS	4
Guide to the steam oven	9
Accessories	11
Before using for the first time	13
Setting the water hardness	13
Setting the altitude	13
Suitable containers	14
Using the steam oven	15
Before each use	15
Selecting a function	15
Adjusting the temperature (if necessary)	15
Selecting the duration	16
Starting a function	16
Interrupting the cooking process	17
At the end of the cooking process	17
After use	18
System lock	19
Cooking tips	20
Steaming	20
Defrosting	23
Reheating	25
Meal planning	26
Special uses	27
Canning	27
Blanching	28
Making Yogurt	28
Disinfecting baby bottles	29
Guide to the functions	30
Automatic Functions	30
Favorites	30

Settings	31
Language 	31
Clock	31
Temperatures	32
Temperature °F / °C	33
Water Hardness	33
Steam Reduction	33
Warming Function	33
Tone Options	34
Display	35
Start Settings	35
System Lock	35
Reset	35
Cleaning and Care	36
Descaling	41
Frequently asked questions	42
After sales service	44
Installation instructions	45
IMPORTANT SAFETY INSTRUCTIONS	46
Appliance and cut out dimensions	48
Installation	51
Electrical connection	52
Caring for our environment	53

IMPORTANT SAFETY INSTRUCTIONS

WARNING- When using your appliance follow basic precautions, including the following:

Read all instructions before installation or use of the steam oven to prevent injury and appliance damage.

Use the steam oven only for its intended purpose. This appliance is intended for residential cooking only.

This appliance conforms to all uniform safety codes and regulations. The manufacturer cannot be held responsible for damage or injury caused by improper use of this appliance.

Keep these operating instructions in a safe place and pass them on to any future user.

SAVE THESE INSTRUCTIONS

Technical Safety

► Before installation make sure that the voltage and frequency listed on the data plate correspond with the household electrical supply. This data must correspond in order to avoid risk of damage to the appliance. If in doubt, consult a qualified technician.

► Installation, repair and maintenance work should be performed by a Miele authorized service technician. Work by unqualified persons could be dangerous and may void the warranty. This data must correspond to prevent injury and appliance damage. If in doubt consult a qualified electrician.

► Be certain your appliance is properly installed and grounded by a qualified technician. To guarantee the electrical safety of this appliance, continuity must exist between the appliance and an effective grounding system. It is imperative that this basic safety requirement be met. If there is any doubt, have the electrical system of the house checked by a qualified electrician. The manufacturer cannot be held responsible for damage caused by the lack, or inadequacy, of an effective grounding system.

IMPORTANT SAFETY INSTRUCTIONS

- ▶ Do not use an extension cord to connect this appliance to electricity. Extension cords do not guarantee the required safety of the appliance, e.g. danger of overheating.
- ▶ Do not operate any appliance with a damaged cord or plug, or if the appliance has been damaged in any manner. Call Miele's Technical Service Department.
- ▶ Always attach the cord to the appliance first, then plug it into the wall outlet. To disconnect, turn the appliance off by pressing the left jog shuttle, then remove the plug from the wall outlet.
- ▶ Do not submerge the plug, cord or steam generator (water tank) into water or attempt to wash the steam generator in the dishwasher. Danger of electric shock!
- ▶ Do not tamper with electrical connections, components or mechanical parts. Never open the outer casing of the appliance.

Use

- ▶ The steam oven should be installed at a safe height for users to safely access all cooking levels and containers. Otherwise spills could cause burns or scalding and children may be put at risk by the hot appliance door.
- ▶ This appliance must only be operated after it has been correctly installed into cabinetry. This is necessary to ensure that all electrical components are shielded.
- ▶ This appliance is intended for domestic use only and is not to be used for commercial purposes.
- ▶ Only use the appliance for its intended purpose. Any other use is at the owner's risk and could be dangerous.
- ▶ This appliance must not be installed or operated outdoors.
- ▶ Do not use plastic containers. They may melt at high temperatures in the oven.
- ▶ To avoid injuries allow the steam oven to cool before cleaning and putting on or taking off parts. Unplug the steam oven from the outlet when not in use and before cleaning.

IMPORTANT SAFETY INSTRUCTIONS

Scalding and Burning hazards

- ▶ When in use the oven, particularly the inside of the door as well as the outer side by the vent, may become very hot and remain so for a while after the oven has been turned off. Keep children at a safe distance.
- ▶ Use pot holders when working with a hot appliance.
- ▶ When handling cooking containers take care not to let the contents spill.
- ▶ Do not touch hot surfaces. Use handles or knobs.
- ▶ Avoid hot steam, serious burns and scalds could result.
- ▶ Use caution when handling the steam generator. Danger of scalding.

Children

- ▶ Close supervision is necessary when any appliance is used by or near children.
- ▶ To reduce the risk of injury, do not allow children to play in, on or near the steam oven.
- ▶ Do not allow children to stand or hang on the appliance door.
- ▶ Do not store items of interest to children in cabinets near the appliance.
- ▶ Use the Child Safety Lock to prevent children from turning on the appliance or changing its settings.
- ▶ The door hinges of the appliance could be hazardous. Ensure that children are kept at a safe distance.
- ▶ Ensure that any plastic wrap, is disposed of safely and kept out of the reach of children. Danger of suffocation!
- ▶ Before discarding an old appliance, switch off and disconnect it from the power supply. Cut off and render the plug useless and remove any doors to prevent hazards.

IMPORTANT SAFETY INSTRUCTIONS

Appliance maintenance

- ▶ Empty the steam generator after every use for hygienic reasons and to avoid condensate water in the appliance.
- ▶ Wipe out the appliance after each use and leave the door open until the moisture in the cooking compartment has evaporated.
- ▶ If the oven is not used for an extended period of time, clean it thoroughly to avoid odors. See "Before using for the first time". Leave the door open after cleaning.
- ▶ Do not use a steam cleaner to clean this appliance. Steam could penetrate electrical components and cause a short circuit. Pressurized steam could cause permanent damage to the surface and to components for which the manufacturer cannot accept responsibility.
- ▶ The appliance is programmed so that after each use residual water will remain in the steam generator. If there is no residual water there is a fault. Contact the Miele Service Department.
- ▶ When descaling the appliance, only use descaling agents available from Miele. Follow the manufacturer's instructions. Do not use vinegar, it will damage the appliance.

Appliance damage

- ▶ Do not heat unopened food containers. Pressure can build up causing an explosion that will damage the cooking compartment. There is also a danger of personal injury and scalding.
- ▶ To prevent condensation which could corrode the appliance, do not leave cooked foods in the oven for an extended period of time.
- ▶ Do not use items in the steam oven which may rust.
- ▶ Do not lean, sit or place heavy items on the open door of the appliance. The door can support a maximum of 17 lbs (8 kg).

IMPORTANT SAFETY INSTRUCTIONS

Further safety notes

▶ In the event of damage or a defect, turn off the appliance immediately. After it has been turned off, isolate it from the main power supply and contact the Miele Technical Service Department. Ensure that power is not restored to the appliance during maintenance or repair work.

▶ Repairs should only be carried out by a Miele authorized service technician in accordance with local and national safety regulations. Repairs and other work by unqualified persons could be dangerous.

▶ While the appliance is under warranty repairs should only be performed by an authorized service technician. Otherwise the warranty is void.

▶ Be sure that cords of other electrical appliances do not come in contact with the appliance door. The insulation of the cords could become damaged creating a hazard.

▶ To protect against electric shock keep the appliance cord clear of liquids.

▶ Do not let the cord hang over the edge of tables or counters, or come in contact with hot surfaces.

▶ The use of accessories not recommended by Miele may cause injury.

SAVE THESE

INSTRUCTIONS

Guide to the steam oven

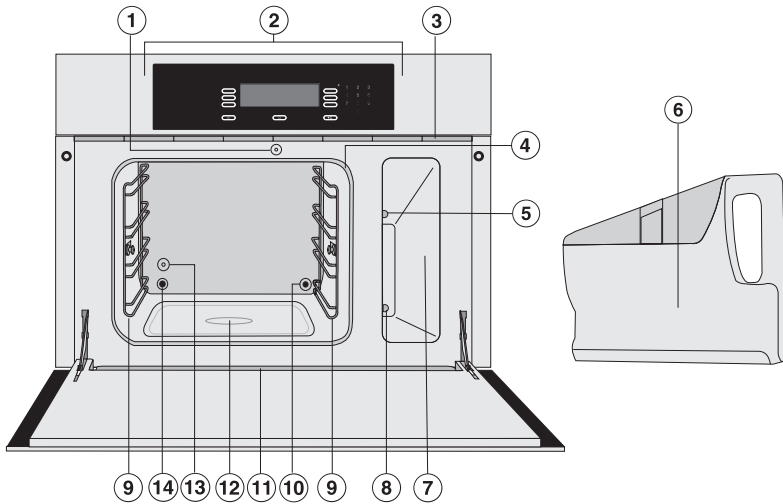

- ① Automatic door opener for steam reduction
- ② Control panel
- ③ Vent for moist air
- ④ Door gasket
- ⑤ Steam channel
- ⑥ Steam generator (with insert)
- ⑦ Steam generator compartment
- ⑧ Steam generator outlet
- ⑨ Side runners with 4 levels
- ⑩ Steam inlet
- ⑪ Drip channel
- ⑫ Bottom heating element
- ⑬ Temperature sensor
- ⑭ Air outlet

Guide to the steam oven

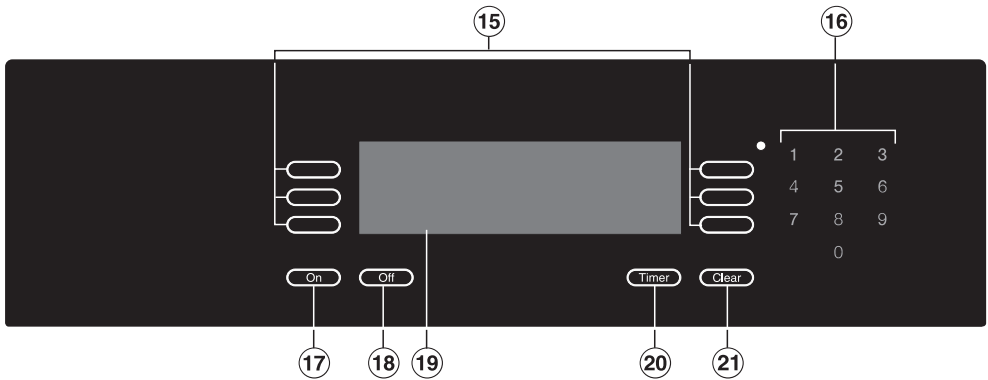

Control panel

- ⑮ **Touch controls**
to select or set a function
- ⑯ **Keypad**
to enter times or temperatures
- ⑰ **On**
to turn the oven on
- ⑱ **Off**
to turn the oven off
- ⑲ **Display**
- ⑳ **"Timer" touch control**
to set a timer independent of an oven function
- ㉑ **"Clear" touch control**
to delete the last entry or to clear menu items

Display

This oven uses soft key technology and an LCD display to assist in the selection of functions.

To select a function, touch the control next to the desired function. The arrow next to each displayed function points to its corresponding control.

Additional functions are displayed by touching the "more" control.

The previous display can be recalled by touching the "back" control.

Dots after a function indicate a submenu. The submenu will appear when the function is selected.

i The display shows information for use. Follow the requests or press "OK" to cancel them from the display.

All accessories can be reordered if necessary.

Drip tray

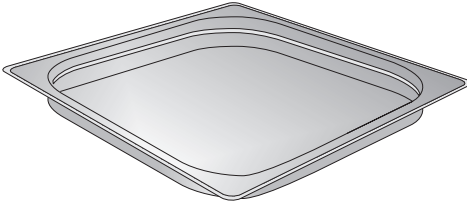

For catching excess liquids

1 cooking container (4.2 pints/2 liters)

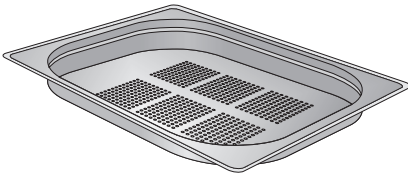

For steaming

2 cooking containers (3.17 pints/1.5 liters)

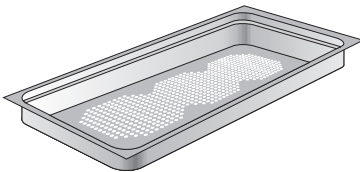

For steaming

Rack

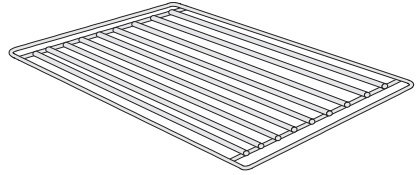

To support cookware

Silicone grease

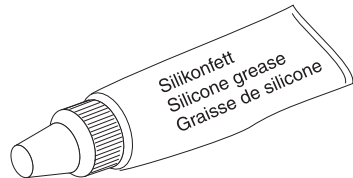

For lubricating the connection valve of the steam generator

Accessories

Optional

The following stainless steel cooking containers for steaming can be ordered as optional accessories:

Container	Capacity in pt (l)	Height in inches (cm)
DGG 2 solid	4.2 (2)	2.5 (6)
DGG 3 solid	6.3 (3.1)	2.5 (6)
DGGL 4 perforated	6.3 (3.1)	2.5 (6)
DGGL 5 perforated	4.2 (2)	2.5 (6)
DGGL 6 perforated	6 (2.8)	4 (10)
DGG 7 solid	6 (2.8)	4 (10)

Container lid DGD

For containers DGG 2, 5, 6, 7

Ceramic cooktop cleaner

Also suitable for cleaning stainless steel

Descaling tablets

To descale the steam generator

Before using for the first time



Setting the water hardness

If your water hardness level differs from the factory setting you will need to reprogram the appliance.

The appliance is factory set to:
8 - 14 gr/gal.

Use the supplied test strip to check your water hardness level or call your local water supplier for the water hardness in your area.

Black squares in the Display	gr/gal	ppm
4	1-7	<20-130
8	8-14	140-250
12	15-21	270-380
16	>21	>380

- Touch the "On/Off" control.
- Select "more" until "Settings ..." shows in the list.
- Select "Settings ".
- Select "Water hardness".
- Set the water hardness by touching the "Softer" or "Harder" control.
- Select "OK" to confirm the setting.

Setting the altitude

This process rinses the water lines and sets the unit to the water boiling temperature which varies depending on the altitude in your area.

- Take the steam generator from the appliance and take the insert out, see "Cleaning and Care".
- Rinse the steam generator and insert with hot water. Do not use any soap.

Do not wash the steam generator or the insert in a dishwasher!

Do not submerge the steam generator in water!

- Start the cooking program "Custom" 212°F (100°C) for 15 minutes. Proceed as described in "Using the steam oven".

When relocating to a new area, reset the unit's water boiling temperature by descaling the appliance. See "Cleaning and Care" for more information.

Setting the altitude for the first time and after relocation will produce more steam than usual. This is not a fault.

Suitable containers

Stainless steel cooking containers are supplied with the appliance.

Other containers are available in a variety of sizes, both perforated and solid, as optional accessories.

Please note when selecting cookware:

- Use perforated cooking containers whenever possible. The steam can reach the food from all sides and cook evenly.
- For thicker items, e.g. potatoes, build larger spaces between them. It is best to space food as much as possible so steam can surround each piece. Larger and deeper containers can be used for larger items.
- Dense dishes such as casseroles or food such as peas or asparagus which have little space between them will take longer to cook because the steam has less space to work in. The more of this type of food the container becomes filled with, the longer the cooking time will be. It is best to use 2 or 3 shallow containers for these foods. The recommended cooking times are for shallow containers. For larger fill heights the cooking time is extended.

See "Cooking tips" for more information.

You can also use your own containers and dishes. However, please note the following:

- The container must be heat resistant up to 212°F (100°C). Heat resistant glass, ceramics, porcelain (chinaware), plastics, stainless steel or enamel dishes are all suitable.
- Food will take longer to cook in a dish with thick sides.
- Place the dish on the supplied rack.
- Ensure that there is a gap of at least 1" (3 cm) between the upper rim of the container and the top of the cooking compartment to allow sufficient steam into the container.

Before each use

- Insert the drip tray to catch condensed water.
- Fill the steam generator with water.

The insert can must remain inside.

Only use **tap water**! Never use distilled or mineral water. Hot water will shorten the heat-up time.

The water level must be between the min and max markings. The marks are on the outside and the inside of the steam generator.

Never exceed the "max" level marker!

The water level in the steam generator is shown in the display by a symbol.

- Insert the steam generator into the appliance until it connects.

Selecting a function

- Open the door and place the food in the oven.
- Touch the "On/Off" sensor.
- Select the sensor of the desired function.

Adjusting the temperature (if necessary)

This oven has been factory tested for the optimum operating temperature of each function.

When using the function "Custom" it is possible to change the default temperature during programming.

- Select the "Temperature" sensor.
- Using the number keys, select the desired temperature.

The default temperatures for the functions "Custom", "Defrost", "Reheat" and "Canning" can be adjusted permanently in the menu "Settings" to customize the oven to your needs. See "Settings - Temperatures" for more information.

Using the steam oven

Selecting the duration

A duration between 1 minute (0:01) and 5 hours 59 minutes (5:59) can be selected for the cooking process.

If the duration is longer than 59 minutes, it has to be set in hours and minutes.

Example: Duration 80 minutes = 1:20.

- Select the desired duration using the number keys.

Cooking time (duration) recommendations are shown in the following tables, see "Cooking tips".

The cooking time depends on the size of the food not on the amount. For example, potatoes with a large diameter need a longer cooking time than ones with a smaller diameter.

The recommended times are stated for an overall amount of 8 - 10 portions. Use suitable cookware.

Starting a function

The oven is factory set to start **automatically** a few seconds after the duration is selected. To start the oven right away select the "Start" sensor.

See "Settings" for more information to set the start permanently to a **manual** start.

After the start a fan noise and a steam generating noise is heard.

During the heating phase the rise in temperature is displayed.

Once the selected temperature is reached, the cooking process starts and the cooking time will elapse.

When cooking cooled or frozen food, the interior temperature is lowered in the beginning then rises very slowly.

The overall time is reached by adding the heat up time and the selected cooking time. The heat up and cooking times depend on the food amount and the food temperature.

Interrupting the cooking process

- You can interrupt the cooking process at any time by opening the door or selecting the "Stop" sensor.

The heating is turned off, the remaining time is stopped.

 Hot steam will escape when the door is opened.

Use caution when taking containers out of the oven. Spilled liquids, steam and the interior walls are hot. Danger of burns!

- Close the oven door to continue cooking.

Once the door is closed, pressure compensation takes place with a whistling sound.

The oven heats up again. Once the selected temperature is reached, the display changes and the remaining time elapses.

At the end of the cooking process

Shortly before the selected time ends, the steam is reduced and the door opens a small gap to release steam.

A tone sounds after the set time has elapsed. The door closes.

- Once the display shows "Ready", open the door and remove the food.

The oven is factory set so that the food will be kept warm at a temperature of 158°F (70°C) for a maximum of 15 minutes if it is not removed from the oven immediately after cooking.

Please note that some food, e.g. fish, can overcook when kept warm.

See "Settings - Steam reduction" and/or "Warming function" to turn off these options.

 Use caution when taking containers out of the oven.

Do not touch hot surfaces.

Avoid hot steam, serious burns and scalds could result.

Using the steam oven

After use

- Turn the appliance off.
- Remove and empty the drip tray.
- Remove and empty the steam generator. Push the steam generator upwards when taking out.
- Clean and dry the appliance after each use. See "Cleaning and Care".
- Leave the steam oven door open to allow the interior to completely dry.

The fan will continue to run for a short time after the appliance is turned off. The fan running time can be shortened by taking out the steam generator immediately after the oven is turned off.

The appliance is set that after each use residual water remains in the steam generator. If there is no residual water, there is a fault. Contact the Miele Service Department.

Timer

The timer can be used to time any activity in the kitchen and can be set independently of a cooking function.

Two alarms (Timer 1 and 2) can be selected simultaneously.

A time between 1 second (00:01 min) and 59 minutes, 59 seconds (59:59 min) can be set.

To set a timer

- Touch the "Timer" control.
- Use the keypad to enter the desired time in minutes and seconds.
- Repeat for the second timer.

The countdown for Timer 1 and 2 is shown in the lower area of the display.

At the end of the timed period, a tone will sound.

- Touch "Clear" to cancel the timer tone.

To cancel a timer

- Touch the "Clear" control.
- Select the control for the timer to be canceled or to cancel both timers and a running function touch "All Functions".
- Select "OK".

System lock

The appliance has a safety lock to prevent it from being accidentally turned on by children.

The appliance comes with the safety lock deactivated. To activate it see "Settings - System lock".

Locking the oven

- Select the symbol .
- Select "On" and confirm with "OK".

Unlocking the oven

- Select the symbol .
- Select "Off" and confirm with "OK".

Cooking tips

Steaming

Food	Function Custom	
	Temperature in °F (°C)	Time in minutes
Vegetables		
Cauliflower, florets	212 (100)	3 - 7
Green beans	212 (100)	5 - 10
Broccoli, florets	212 (100)	2 - 8
Peas, Green	212 (100)	40
Peas, Black	212 (100)	60
Carrots, cut	212 (100)	3 - 12
Potatoes, peeled and halved	212 (100)	20 - 25
Potatoes, unpeeled	212 (100)	25 - 28
Brussels sprout	212 (100)	12 - 14
Asparagus	212 (100)	4 - 8
Turnips, cubed	212 (100)	7 - 14
Meat or Deli		
Sausage	194 (90)*	2 - 4
Smoked pork chops	212 (100)	6 - 8
Chicken	212 (100)	50 - 60
Fish		
Salmon fillet	212 (95)	4 - 12
Flounder fillet	185 (75)	4 - 12

* This temperature does not reflect the default temperature.

Cooking tips

Food	Function Custom	
	Temperature in °F (°C)	Time in minutes
Casserole		
Meat casserole	212 (100)	10 - 12
Rice casserole	212 (100)	20 - 25
Legumes		
Beans, soaked	212 (100)	25 - 60
Peas, soaked	212 (100)	20 - 40
Lentils, not soaked	212 (100)	20 - 25
Rice and Grain		
Soaking grains, whole	212 (100)	16 - 35
Soaking grains, ground	212 (100)	10
Rice	212 (100)	20
Eggs		
Eggs, soft	212 (100)	4 - 7
Eggs, medium	212 (100)	6 - 8
Eggs, hard	212 (100)	10 - 12
Fruit		
Apple/Pear pieces	212 (100)	2 - 6
Rhubarb	212 (100)	2 - 4
Cherries	212 (100)	1 - 2

Cooking tips

Tips for steaming

- The cooking times for cooking with steam are almost the same as cooking in a pot.
- The steam prevents the food from drying out and the disadvantages come with it. The food stays moist and juicy. The same is true not only for vegetables but also for desserts, fish and meat recipes.
- You can cook on any level or on multiple levels at a time. The cooking time will not change.
- The food will not brown and does not get a crust. The food is gently steamed, not fried or baked. Cheese will melt but not brown. Steaming food is healthy and accentuates its flavor.
- When cooking frozen food, e.g. vegetables, break up large clumps so they cook evenly. The cooking time is approximately the same as for fresh vegetables.
- Frozen and fresh vegetables with the same cooking time can be steamed together.
- Since steam cooking retains flavors so well, food should not be seasoned until after it has been cooked.
- When cooking with liquids only fill the containers $\frac{3}{4}$ of the way.
- Food like noodles or rice need to be cooked in fluids. Noodles should be well covered with fluid. Rice, beans and cereals need to be cooked in equal amounts of food and water.
- Follow the cooking time for pasta on the packaging.
- The cooking liquid gets absorbed by some food (e.g. rice). With other food it can be used for gravy or sauces.
- You can prepare gravy in the steam oven by adding flour and butter to the liquid.
- Grease the perforated container when cooking fish. Grease the solid container when cooking eggs, e.g. scrambled eggs.
- To avoid any transfer of tastes caused by moisture dripping from above, perforated containers should be inserted in the lower runner and the solid containers should be placed on the rack in an upper level.
- Yeast dough can be proofed in the steam oven. Select the "Custom" function and lower the default temperature to 104°F (40°C). Cover the dough.
- The weight in the automatic program is the weight per piece. The setting - and therefore the cooking time - stay the same, regardless if you cook only one piece of salmon 0.5 lbs or ten pieces of salmon 0.5 lbs at the same time.

Defrosting

Function Defrost				
Food to be defrosted	Weight in ounces (grams)	Temperature in °F (°C)	Thaw time in minutes	Compensation time in minutes
Meat				
Ground meat	9 (250)	122 (50) *	15-20	10-15
Steaks or sausage	28 (800)	140 (60)	25-35	15-20
Poultry				
Chicken	35 (1000)	140 (60)	40	15-20
Chicken drum sticks	5.5 (150)	140 (60)	20-25	10-15
Chicken breast	17.5 (500)	140 (60)	25-30	10-15
Fish, Seafood				
Fish fillets	14 (400)	140 (60)	15	10-15
Shrimp	10.5 (300)	140 (60)	4-6	5
Vegetables				
Frozen in a block	10.5 (300)	140 (60)	20-25	10-15
Frozen	12.5 (350)	140 (60)	15	8-10
Fruit				
Apple sauce	9 (250)	140 (60)	20-25	10-15
Berries	10.5 (300)	140 (60)	8-10	10-12
Dairy products				
Cheese	5 (100)	140 (60)	15	10-15
Heavy cream	9 (250)	140 (60)	20-25	10-15
Cookies				
Pastries	-	140 (60)	10-12	10-15
Yeast dough pastries	-	140 (60)	10-12	10-15
Function Custom				
Bread	9 (250)	212 (100)	10-15	10-15
Bread rolls	-	212 (100)	6-7	1-2

* This temperature does not reflect the default temperature.

Cooking tips

Defrosting frozen foods

Defrosting times depend on the type and weight of the food and at what temperature it was deep-frozen.

- Insert the food in a container or on the rack.
- Select the function "Defrost".
- If desired, adjust the default temperature (see table).
- Select the defrost time (see table).
- Allow food to stand at room temperature after defrosting. This standing time (see table) is necessary to ensure that the food is fully defrosted.

Tips for defrosting

 Do not cook with defrosting liquids.

- When defrosting poultry, set the food on the rack and insert the drip tray beneath it. This prevents the food from lying in the defrosting liquid.
- To defrost non dripping food, remove the wrapping and place it on the rack or in a container.
- Fish does not need to be fully defrosted before cooking. Defrost it so that the surface is sufficiently thawed to take herbs and seasoning. Fish coated with breadcrumbs should be fully defrosted so that the coating sticks.
- Turn, stir or separate food about halfway through the defrosting period.
- Do not refreeze food once it has been defrosted.
- Defrost deep frozen, precooked meals according to the manufacturer's instructions.
- Defrost baked items such as pastry or cakes in a closed freezer bag.

Reheating

Function Reheat	
Food to be reheated	Time in minutes
Vegetables	
Cauliflower, Beans	2
Turnips, Carrots	2
Side dishes	
Potatoes (cut lengthwise) Dumplings	3-4
Pasta, Rice	2-3
Meat and poultry	
Roast in slices ½" (1.5 cm) thick	3-5
Chicken breast	3-5
Meatballs	3-5
Roulades, sliced	3-5
Fish	
Fish fillets	2-3
Fish roulade, halved	2-3
Complete dish	
Chicken fricassee with rice	3-5
Pork roast with potatoes and vegetables	3-4
Spaghetti with tomato sauce	2-3
Soups/Stews	
Stew	4-5
Vegetable/Cream soups	2-3

The steam oven can be used to reheat dishes.

- Place the food on a flat plate and cover it with a deeper plate or aluminum foil.
- Select "Reheat".
- Select the time (see table).

Tip

Reheat sauces which are to be served on the side e.g. gravy, hollandaise, in a separate, covered container.

Meal planning

With some planning, an entire meal can be cooked in the steam oven. The "Steam reduction" feature must be turned off.

- Place cooking containers on different levels or place them side by side on the rack.

In general, cooking durations will vary according to the type of food. This means that you will need to open the steam oven at different times to add a particular dish. Our test kitchen recommends the following procedure, as shown in this example (Function: Custom / 212°F (100 °C)).

Rice	20 minutes
Fish fillet	6 minutes
Broccoli	4 minutes

- First place the dish with the longest cooking duration (the rice), in the oven and set a duration of 20 minutes.
- As soon as the set temperature has been reached, set the timer for the difference between the first and second cooking durations, i.e. the time until the second dish has to be placed in the oven (14 minutes). Confirm with "OK".
- When the timer sounds, place the second dish (the fish fillet) in the oven.
- As soon as the set temperature has been reached, set the timer for the time until the third dish (the broccoli) has to be placed in the oven (2 minutes). Confirm with "OK".
- When the timer sounds, place the third dish (the broccoli) in the oven.
- At the end of the cooking duration you can remove all the dishes at the same time.

Canning

Function Canning		
Canning food	Temp. in °F (°C)	Time in minutes
Fruit		
Apples	194 (90) *	50
Apple sauce	194 (90) *	65
Peaches/ plums	185 (85) *	55
Currants	176 (80) *	50
Vegetables		
Beans	212 (100)	120
Cucumbers	194 (90) *	55

* This temperature does not reflect the default temperature.

The given times are for 1 liter jars. For ½ liter jars the times are shortened by 15 minutes, for ¼ liter jars the time shortens by 20 minutes.

- Insert the rack in the lowest runner.
- Place up to 6 jars (even in size) on the rack, so that they do not touch each other. The steam can surround the jars.
- Select the function "Canning".
- If desired adjust the default temperature (see table).
- Select the time (see table).
- Use the residual heat by leaving the jars in the oven for another 30 minutes after turning the oven off.

Cover the jars with a towel and allow them to cool for 24 hours.

Special uses

Blanching

The steam oven can also be used to blanch vegetables and fruit to prepare them for freezing

- Put the prepared vegetables/fruit (cleaned, washed, chopped, etc.) into a perforated container.
- Place the container in the oven and insert the drip tray at the lowest level.
- Select "Custom".
- Set a duration of 1-2 minutes.
- Once blanched, plunge the vegetables/fruit into ice water.

You can then freeze them once they have dried thoroughly.

Making yogurt

Ingredients: 3.5 oz (100 g) yogurt (with live cultures) and 1 quart (1 l) of pasteurized or fresh whole milk. Yogurt and milk must have the same fat contents.

- Heat (do not boil) fresh milk to 194°F (90°C), let it cool before mixing together with the yogurt. This is necessary to give the yogurt a firm texture.
- Fill 6 yogurt jars with the mixture and cover with aluminum foil.
- Set the covered jars on the rack.
- Select "Custom" and lower the default temperature to 104°F (40°C).
- Set a duration of 5 hours.
- Let the yogurt cool and store in the refrigerator.

Once the yogurt has cooled completely it will have a firm texture.

Disinfecting baby bottles

The steam oven can be used to disinfect baby bottles and other containers. Check beforehand that all parts are heat resistant to 212 °F (100 °C).

- Place the drip tray on the lowest runner level and place the rack above it.
- Dismantle, clean and thoroughly rinse the bottles. Space the individual parts out on the rack, ensuring that they do not touch one another. This allows the hot steam to reach all sides.
- Select "Custom". The recommended temperature of 212 °F (100 °C) is suitable for disinfection.
- Set a time of 15 minutes.

Allow the bottles to dry naturally and use them as soon as possible after disinfection. All parts of the bottles must be completely dry before they are reassembled.

Guide to the functions

Automatic Functions

The following automatic programs are available:

Vegetables

Fish

Poultry

Meat

Eggs

Grains

Fruit

You can select from a variety of foods in these programs. Cooking temperatures and times are preselected. You only need to select the desired defaults.

For many vegetables and fruits a middle cooking grade is set by default. Cooking grades from "al dente" to "soft" are available.

Favorites

If you often cook a recipe with the same settings (function, time, temperature) you can save them as a "Favorite" for easy recall. Up to 30 favorites can be saved.

To save a Favorite

- Enter the function, temperature and cooking times of the recipe. The oven will begin heating.

- Touch the "Add to Favorites" control.

Your "Favorite" must be named before it can be saved into memory.

- Enter the letters and numbers of the name by touching the controls left and right of the alpha-numeric list. Confirm each character entry by touching the "Select" control.

- Touch the "OK" control when naming is complete to save the "favorite" to memory.



Your "Favorite" can now be recalled from the "FAVORITES" list. When selected, the oven will automatically use the saved settings.

Touch "Clear" to cancel the running function if you are not cooking.

The default oven settings can be changed in the function "SETTINGS". In this function you can customize the oven to suit your preferences. Settings may be adjusted by touching the appropriate touch control.

Language

- Select the desired language and confirm by touching "OK".

The  symbol indicates the "Language" setting. If the oven was set to an unfamiliar language, look for the  symbol. Touch flag control and select the language of choice.

Clock

"Enter Time" appears in the display.

- Enter the current time using the keypad.

Different settings can be selected by touching the control next to the option:

- The size of the clock display
 - Size Normal
 - Size Large
- The time format
 - 12 Hour
 - 24 hour
- Whether or not the time is displayed
 - Clock-Display On
 - Clock-Display Off
- Touch the "OK" control to confirm the entries.

If power to the oven is cut off for more than 4 days, the clock will have to be reset.

Settings

Temperatures

The default temperature of each function can be adjusted within the ranges shown below. If a temperature selected is out of range, the oven will revert to the default temperature.

- Touch the control of the function whose default temperature you wish to alter.
- Enter the new default temperature using the keypad.
- Touch the "OK" control to confirm.

The next time this function is selected, the new temperature will be used as the default.

Function	°F		°C	
	Default	Range	Default	Range
Custom	212 °F	105 - 212 °F	100 °C	40 - 100 °C
Defrost	140 °F	125 - 140 °F	60 °C	50 - 60 °C
Reheat	212 °F	175 - 212 °F	100 °C	80 - 100 °C
Canning	212 °F	175 - 212 °F	100 °C	80 - 100 °C

Temperature °F / °C

All oven temperatures can be displayed in either Fahrenheit or Celsius.

- Touch the "TEMPERATURE" control to toggle between °F and °C.

Water Hardness

The oven can be set to the water hardness in your area. See "Setting the water hardness".

Steam Reduction

This function can be turned on or off.

The "Off" option is recommended when food is cooked at the same time but inserted at different times. Please note when the oven door is opened a great deal of steam will expel and the function "Warming" cannot be used.

- Touch the control of the desired setting.
- Touch "OK" to confirm.

Warming Function

The oven is factory set so that the food will be kept warm at a temperature of 158°F (70°C) for a maximum of 15 minutes if it is not removed from the oven immediately after cooking. Please note that some food, like fish, can overcook when kept warm.

- Touch the control of the desired setting.
- Touch the "OK" control to confirm.

Settings

Tone Options

Unique tones may be set for each of the two timers to differentiate the timers from an oven function tone.

Timer 1 and Timer 2

The tone of Timer 1 and Timer 2 can be set to one of five tone options.

- Select "Timer 1 Tone" or "Timer 2 Tone" by touching the corresponding control.

With every touch of the respective control, another tone will sound and the display will show the tone number. For example, Timer1 Tone 1.

- Select the tone for each timer.

Keypad tone

The keypad can be set to make a sound with every touch of a control.

- Touch the "Keypad tone" control to toggle between the on and off settings.

Volume

This control adjusts the volume of the tone options.

- Touch the "Volume" control until you hear the desired volume.

Tone Short / Long

The duration of the timer and oven tones can be modified.

- "Tone short" will beep in quick succession when an oven signal or the oven timer sounds.
- "Tone long" a continuous tone will sound when an oven signal or the oven timer sounds.

- Touch the "Tone" control to toggle between the short and long setting.
- Touch the "OK" control to confirm the setting.

When the tone sounds to indicate an oven signal or the timer, touch any number on the keypad to turn off the tone.

Display

The brightness and contrast of the oven display can be adjusted by touching the controls next to "Brightness" or "Contrast".

Start Settings

The oven can be set for an automatic start 20 seconds after the last setting or to be started manually.

- Select the desired setting.
- Touch the "OK" control to confirm.

System Lock

If "Accept" is selected, the System Lock can be activated when the oven is turned off.

- Select the desired setting.
- Touch the "OK" control to confirm.

Reset

The factory settings of the oven can be restored through the "Reset" function.

Reset Temperatures

If the request is confirmed with "yes", all changed temperatures will be restored to the factory default.

Reset Settings

If the request is confirmed with "yes", all changed settings will be restored to the factory default.

Reset Favorites

If the request is confirmed with "yes", all "Favorite" entries will be deleted. Once deleted, these entries cannot be restored.

Cleaning and Care

General

- Clean and dry the steam oven after each use. Let the appliance cool before cleaning.
- Close the door only after the cooking compartment is completely dry.

Do not use a steam cleaner to clean this appliance. Pressurized steam could penetrate electrical components and cause a short circuit.

Never use abrasive cleaners, scouring pads, steel wool or caustic (oven) cleaners on the appliance. Hard brushes or scouring cloths which still have abrasive materials on them should not be used. They **will** damage the surface.

Only use liquid dishwashing detergent.

Appliance front

- Clean the front and the control panel with a solution of hot water and liquid dish soap applied with a soft sponge.
- Dry with a soft cloth.

Glass surfaces

- Use a glass cleaner.

Stainless steel surfaces

- Stainless steel surfaces can be cleaned using a non-abrasive stainless steel cleaner.
- To help prevent resoiling, a conditioner for stainless steel can also be used. Apply sparingly with even pressure in the direction of the grain. It can be purchased from Miele.

Removing the door

Removing the door will make it easier to reach into the oven interior.

- Open the appliance door.

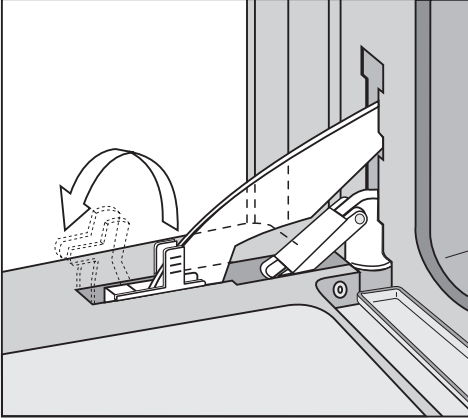

- Flip up the clamps at the front of the door hinges.
- Slowly close the door until the clamps are touching the frame of the oven interior.

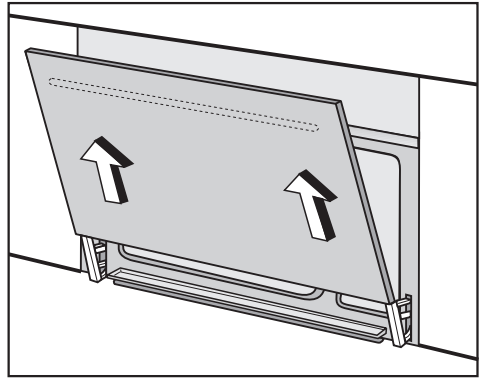

- While holding the door with both hands, lift the door until the hinges disengage. Remove the door.

To refit the door

- Place the door on the hinges and slide down.
- Open the door fully.
- Push the clamps back down.
- Close the door.

Cleaning and Care

Oven interior

The cooking compartment including ceiling, door gasket, drip channel, door interior and steam generator niche should be cleaned after each use.

- Most cooking residues can be easily removed using a sponge, liquid detergent and warm water.
- Wipe the interior with clean water and dry with a soft cloth.

The bottom heating element may become discolored over time from dripping liquids.

- The discoloration can be removed with the Miele ceramic cooktop cleaner, which is also suitable for stainless steel. See "Accessories - Optional".
- Wipe with clean water until all cleaning residues are removed.

If the door gasket is damaged, it must be replaced. A door gasket can be purchased from Miele.

Drip tray, rack, cooking containers

- Wash and dry the drip tray, rack and cooking containers after each use either by hand or in a dishwasher.

Automatic door opener

- Keep the door opener clean. Clean any food residues with a sponge and a solution of warm water and liquid dish soap. Wipe with clean water.

Runners

The side runners can be removed before cleaning the cooking compartment.

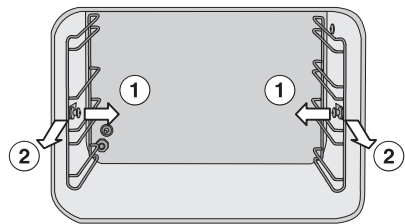

- Pull on the knobs to release the runners ①. Then pull each runner out of the oven ②.
- The runners can be cleaned with water and dish soap or in a dishwasher.
- To refit the runners, reverse the above steps. Insert them into the rear of the oven and push in at the sides.

Steam generator

Do not submerge the steam generator in water or wash it in the dishwasher!

Empty the steam generator after each use to avoid condensate water build-up.

Do not use hard brushes or sponges for cleaning.

- Take out the steam generator after each use, empty and dry. Remove the insert before cleaning and drying.

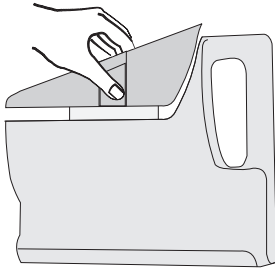

- Remove the insert by pressing the handles together and lift upwards at an angle.

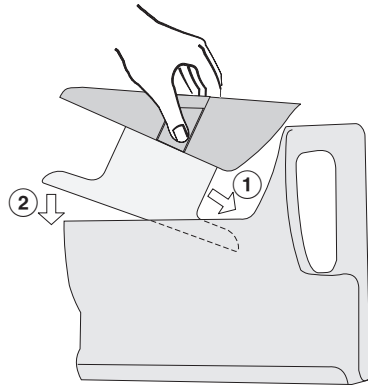

- Reinsert the insert into the steam generator only when both parts are dry. Place the insert in at an angle ① and lower the side with the opening ②.

Cleaning and Care

Connection valve

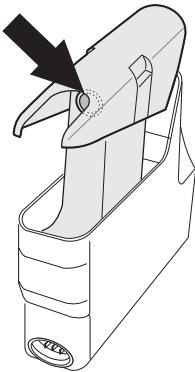

If the connection valve becomes brittle, dried out or if a lot of water collects at the bottom of the steam connector niche, the valve needs to be replaced.

An valve can be purchased from Miele.

When lubricating the valve only use the silicone grease supplied. Never use margarine, oil, or any other grease or fat on the valve, they will cause deterioration.

If the steam generator becomes difficult to insert and remove or if the fault message F20 appears, the connection valve must be lubricated.

The connection valve is the upper connection in the cut out area.

- Lubricate the connection valve (not the plug in the lower part) with a very small amount of the supplied silicone grease, see "Accessories". Leave the valve on the connector while doing so.

Take care when using silicone grease.

- Remove any silicone grease from your skin by washing with soap and water.
- If silicone gets into the eyes flush with plenty of clean water.
- If silicone is swallowed seek medical attention.

Descaling

When descaling the oven, only use descaling tablets available from Miele. Follow the manufacturer's instructions.

The display will show a message stating that the appliance needs to be descaled.

The display will also show that after "x" numbers of uses the appliance will be locked if not descaled.

Once locked the appliance cannot be used until the descaling program has been run.

If you want to descale before the appliance is locked, select the function "Descaling".

- Contact Miele to order descaling tablets.
- Dilute the descaling agent with water to make 1 quart (1 Liter) of solution in the steam generator. Follow the manufacturer's instructions.
- Push the steam generator into the appliance until it engages.
- Follow the prompts.

The descaling can be canceled during the first minute. After that the process cannot be stopped.

Do not turn the appliance off during the descaling process! If it is turned off before the end of the program the entire process will have to be restarted.

At the end of the process

- Open the door.
- Remove and empty the steam generator.
- Turn the steam oven off and dry it thoroughly.

Frequently asked questions

Repairs should only be carried out by an authorized technician in accordance with local and national safety regulations. Unauthorized repairs could cause injury or appliance damage.

The oven cannot be turned on.

Possible fault	Solution
There is no power to the steam oven.	Reset the circuit breaker if it has tripped. If this is not the case, disconnect the appliance from the power supply for 1 minute. Reconnect the power and turn the appliance on. If it still does not heat, contact Miele Technical Service.

The fan can still be heard after the appliance has been turned off.

Possible fault	Solution
The appliance has a fan which removes steam from the oven.	The fan will continue to run for a while after the oven has been turned off.

The steam generator is difficult to insert or remove.

Possible fault	Solution
The connection valve at the steam connector needs to be lubricated.	Lubricate the connection valve (not the electrical connection!) with a small amount of the supplied silicone grease. See "Cleaning and care - Connection valve".

The heating phase takes an unusually long time.

Possible fault	Solution
Check the bottom of the steam generator. If there are calcium deposits, check the water hardness level setting.	Set the level to the water hardness of your area. See "Setting the water hardness". Descal the steam oven as described in "Descaling". If the water hardness is set correctly or if the problem persists, call Technical Service.

Frequently asked questions

The oven does not change from the heating to cooking phase after relocation.	
Possible fault	Solution
The oven must be reset to a new location and/or boiling temperature of the water.	See "Setting the altitude".
A great deal of steam comes out of the appliance while in use, or steam comes out of unusual locations.	
Possible fault	Solution
The door is not properly closed.	Close the door.
The door gasket does not fit properly.	Press it on, so it evenly fits.
The door gasket is damaged.	The gasket must be replaced. If the problem persists, call Technical Service.
A whistle sounds when the cooking is resumed.	
Possible fault	Solution
Once the door is closed pressure is vented with a whistling sound.	This is not a fault.
The display shows a <i>F</i> with a number.	
Possible fault	Solution
F 20 The oven does not heat.	Check if the steam generator is inserted all the way by removing it and inserting it again. Turn the steam oven off and on again. If the fault occurs again, lightly lubricate the connection valve of the steam generator with silicone grease, as described in "Cleaning and care - Connection valve". If the problem persists, turn the appliance off and call Technical Service.
Other fault messages	Call the Miele Technical Service Department.

After sales service

In the event of a fault which you cannot correct yourself please contact the Miele Technical Service Department at the phone numbers listed on the back of this booklet.

When contacting the Technical Service Department, please quote the model and serial number of your appliance. These are shown on the data plate.

MieleCare

(USA only)

MieleCare, our Extended Service Contract program, gives you the assurance of knowing that your appliance investment is covered by 5 years of worry free ownership.

MieleCare is the only Extended Service Contract in the industry that guarantees repairs by a Miele Authorized Service Provider using genuine Miele parts. Only genuine Miele parts installed by factory trained professionals can guarantee the safety, reliability, and longevity of your Miele appliance.

Please note that unless expressly approved in writing by Miele's Service department, Extended Service Contracts offered by other providers for Miele products will not be recognized by Miele. Our goal is to prevent unauthorized (and untrained) service personnel from working on your Miele products, possibly doing further damage to them, you and/or your home.

To learn more about **MieleCare** Extended Service Contracts, please contact your appliance dealer or visit us online at:

<http://miele.com/mielecare>

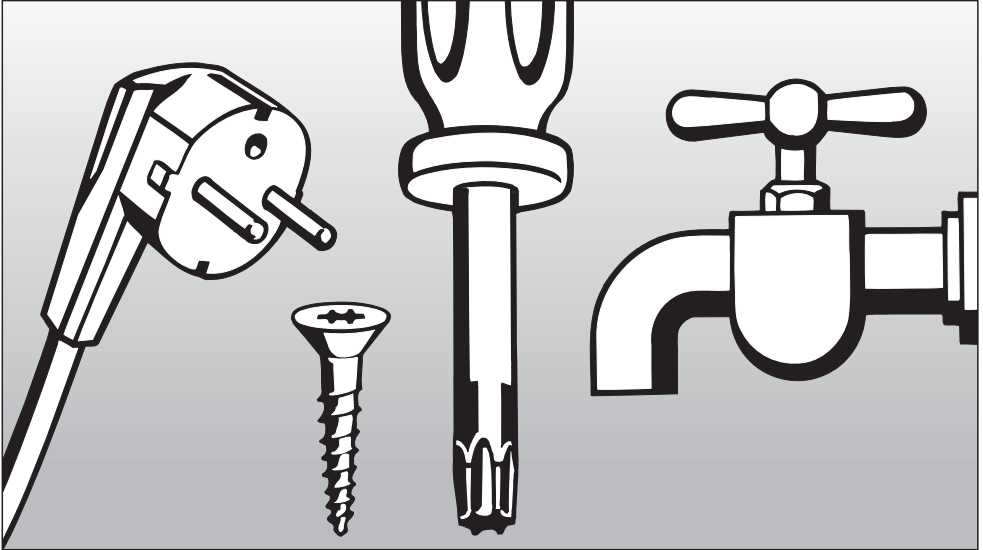

Installation Instructions

To prevent accidents
and machine damage
read these instructions
before
installation or use.

IMPORTANT SAFETY INSTRUCTIONS

 **WARNING** - Read all instructions before installation or use of the steam oven to prevent injury and machine damage.

▶ Before installation make sure that the voltage and frequency listed on the data plate correspond with the household electrical supply. This data must correspond to prevent injury and machine damage. Consult a qualified electrician if in doubt.

▶ Installation, repair and maintenance work should be performed by a Miele authorized service technician. Work by unqualified persons could be dangerous and may void the warranty.

▶ Before installation or service, disconnect the power supply to the work area by removing the fuse, "tripping" the circuit breaker or switching off the power main. Ensure that power is not restored to the appliance during maintenance or repair work.

▶ Do not use an extension cord to connect this appliance to electricity. Extension cords do not guarantee the required safety of the appliance, (e.g. danger of overheating).

▶ Do not operate any appliance with a damaged cord or plug or if the appliance has been damaged in any manner. Return the appliance to the nearest authorized service facility for examination, repair or adjustment.

▶ Inspect the steam oven for shipping damage. Do not install or operate a damaged unit. Contact the place of purchase.

▶ The steam oven should be installed at a safe height for users to safely access all cooking levels and containers.

▶ This equipment is not designed for maritime use or for use in mobile installations such as recreational vehicles or aircraft. However, under certain conditions it may be possible for an installation in these applications. Please contact the nearest Miele dealer or the Miele Technical Service Department with specific requirements.

IMPORTANT SAFETY INSTRUCTIONS

- ▶ This steam oven is designed for installation in cabinetry or beneath a countertop. This is necessary to ensure that all electrical components are shielded.
- ▶ Be certain your appliance is properly installed and grounded by a qualified technician. To guarantee the electrical safety of this appliance, continuity must exist between the appliance and an effective grounding system. It is imperative that this basic safety requirement be met. If there is any doubt, have the electrical system of the house checked by a qualified electrician.
- ▶ Do not tamper with electrical connections and components or mechanical parts. Never open the outer casing of the appliance.

Note to the installer:

Please leave these instructions with the consumer of the appliance for the local building inspectors use.

SAVE THESE INSTRUCTIONS

Appliance and cut out dimensions

Miele appliances can be installed flush or proud. Discuss your installation requirements with your architect, designer and installer.

Installation in a tall cabinet

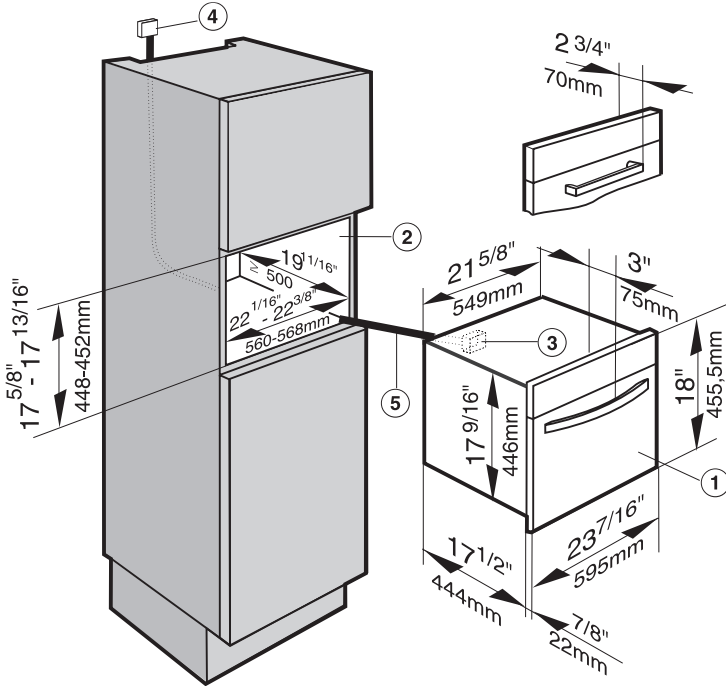

- ① Steam oven
- ② Cabinet opening
- ③ Terminal block
- ④ Outlet or junction box
This should be accessible after the appliance has been installed.
- ⑤ Power cord

- * Machine with glass front
- ** Machine with stainless steel front

Appliance and cut out dimensions

Installation under a countertop

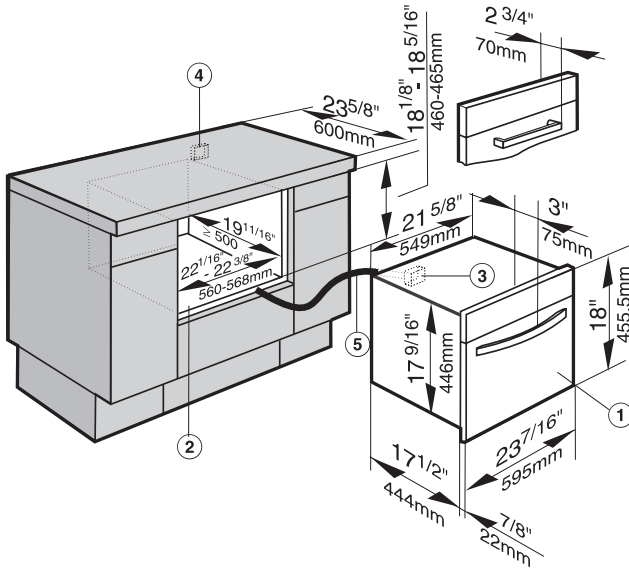

① Steam oven

② Cabinet opening

③ Terminal block

④ Outlet or junction box

This should be accessible after the appliance has been installed.

⑤ Power cord

* Machine with glass front
** Machine with stainless steel front

Appliance and cut out dimensions

Installation above a Miele oven

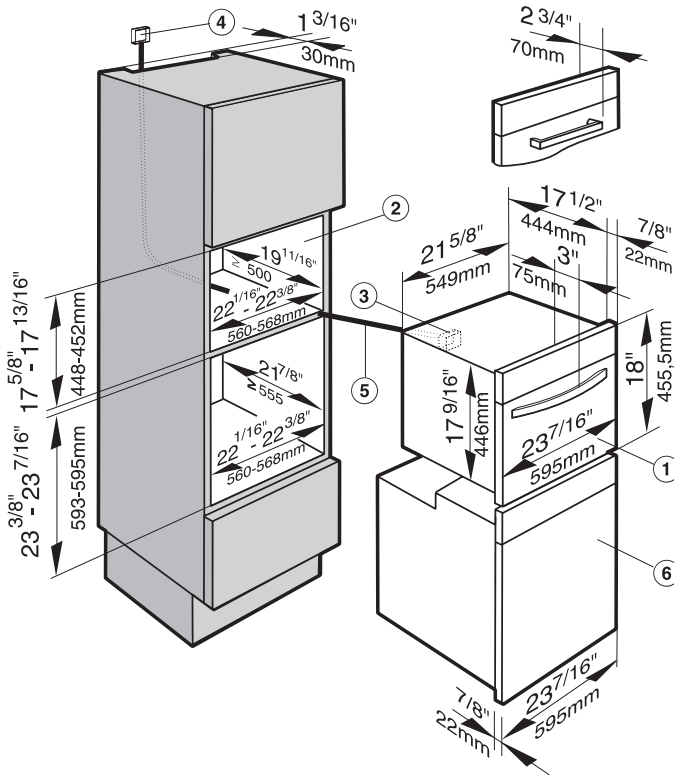

- ① Steam oven
- ② Cabinet opening
- ③ Terminal block
- ④ Outlet or junction box
This should be accessible after the appliance has been installed.
- ⑤ Power cord
- ⑥ Oven

- * Machine with glass front
- ** Machine with stainless steel front

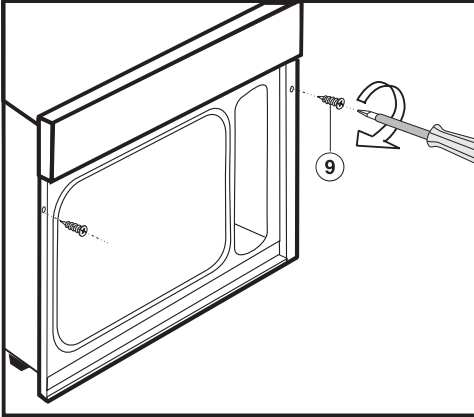

- Push the appliance into the niche. After aligning the oven it must be secured in position. Open the oven door and using the two supplied screws ⑨, secure it to the cabinet through the holes on either side of the vertical oven trim.

Electrical connection

Installation, repairs and other work by unqualified persons could be dangerous.

The appliance comes equipped with a 6 ft (1.8 m) power cord with a NEMA 6-15P molded plug for connection to a 240 V, 15 A, 60 Hz power supply.

Connection should be made via a suitable isolator, with an on-off switch which should be easily accessible for servicing work.

Verify that the voltage, load and circuit rating information found on the data plate, match that of the household electrical supply before installing the appliance.

If there is any question concerning the electrical connection of this appliance to your power supply, please consult a licensed electrician or call Miele's Technical Service Department.

 1-800-999-1360

 1-800-565-6535

Disposal of packing material

The transport and protective packing materials are environmentally friendly for disposal and may be recyclable.

Ensure that any plastic wrap is disposed of safely and kept out of the reach of children. Danger of suffocation! Danger of suffocation!

Disposal of an old appliance

Old appliances may contain materials that can be recycled. Please contact your local recycling authority about the possibility of recycling these materials.

Before discarding an old appliance ensure that it presents no danger to children while being stored for disposal. Unplug it from the outlet, cut off its power cord and remove any doors to prevent hazards.

**Please have the model and serial number
of your appliance available before
contacting Technical Service.**



U.S.A. Miele, Inc.

National Headquarters

9 Independence Way
Princeton, NJ 08540
Phone: 800-843-7231
609-419-9898
Fax: 609-419-4298
www.mieleusa.com

Technical Service & Support Nationwide

Phone: 800-999-1360
Fax: 888-586-8056

TechnicalService@mieleusa.com

Canada Miele Limited

Headquarters and Showroom

161 Four Valley Drive
Vaughan, ON L4K 4V8
Phone: 800-643-5381
905-660-9936
Fax: 905-532-2290
www.miele.ca
professional@miele.ca
(commercial enquiries)

MieleCare National Service

Phone: 800-565-6435
905-532-2272
Fax: 905-532-2292
customercare@miele.ca
(general and technical enquiries)

Germany

Miele & Cie. KG
Carl-Miele-Straße 29
33332 Gütersloh