

TXR 860 WP Heat Pump Dryer

Features:

- Ventless Heat-Pump Dryer (120 V, 15 A)
- Honeycomb drum (4.03 ft³ capacity)
- PerfectDry moisture sensing technology
- M Touch premium user interface
- 19 Programs including SoftSteam
- FragranceDos²
- EnergyStar Most Efficient



MATERIAL #	EAN #
11620030	4002516379836

SPECIFICATIONS	
Overall Unit Dimensions	23 ¹ / ₂ " (596 mm) W x 33 ¹ / ₂ " - 34 ³ / ₄ " (850 - 882 mm) H x 25 ⁵ / ₁₆ " (643 mm) D
Niche	
Minimum Cabinet Niche Opening	23 ³ / ₄ " (603 mm) W x 33 ⁵ / ₈ " (854 mm) H x 24" (610 mm) D
Plumbing	
Drain Hose (Supplied)	Length: 5 ft 3 in. (1.6 m)
Electrical	
Electrical Requirements	110 V / 120 V, 60 Hz, 15 Amps
Power Cord	NEMA 5-15 plug, 6 ft 6 in. (2 m)
Shipping	
Shipping Weight	137 lbs (62 kg)
Shipping Dimensions	26" W x 37" H x 27 ³ / ₁₆ " D

PRODUCT DIMENSIONS

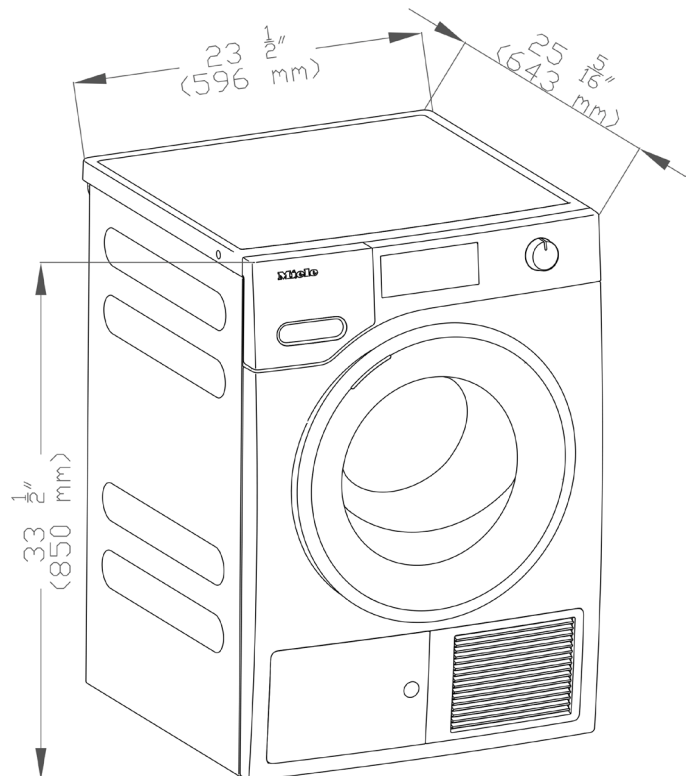

ADDITIONAL PRODUCT

DIMENSIONS

Side View

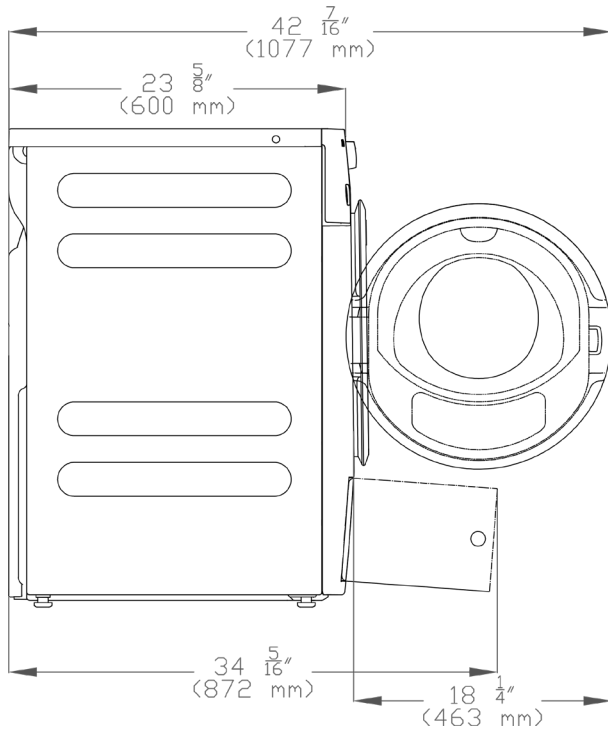

Rear View

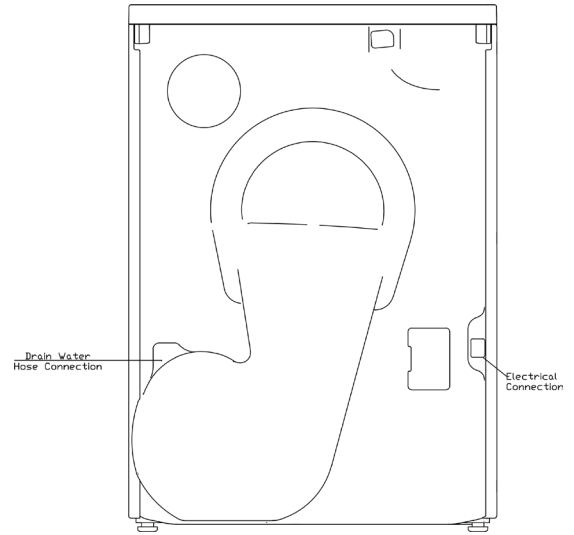

NICHE DIMENSIONS

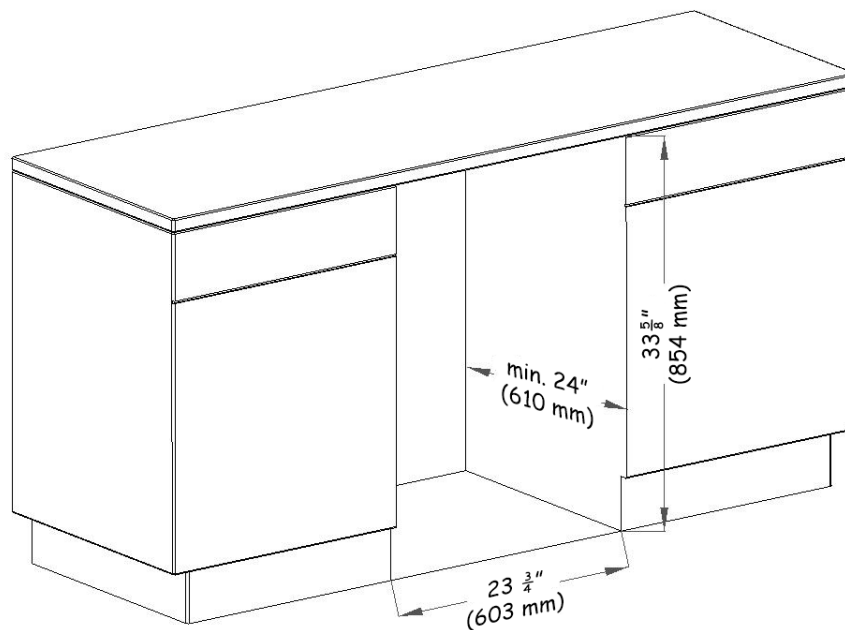

OPTIONAL ACCESSORIES

WTV502

Material# 9256140

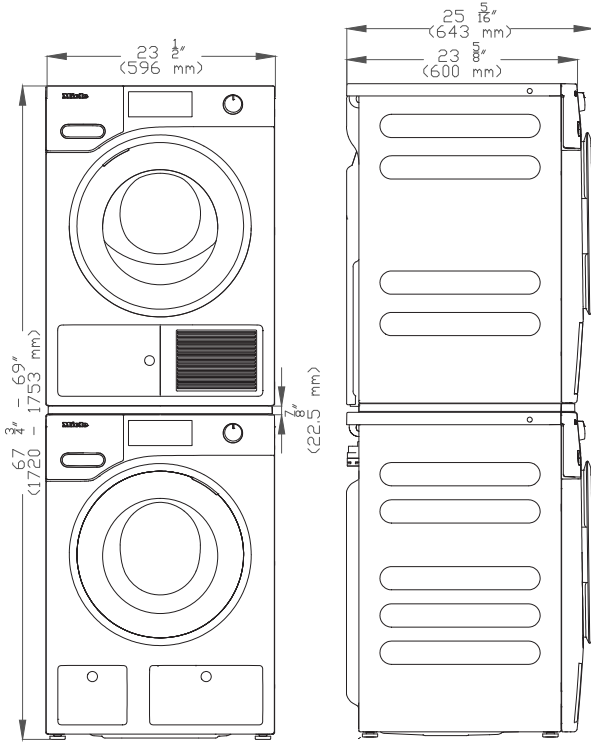

WTV512

Material# 9351790

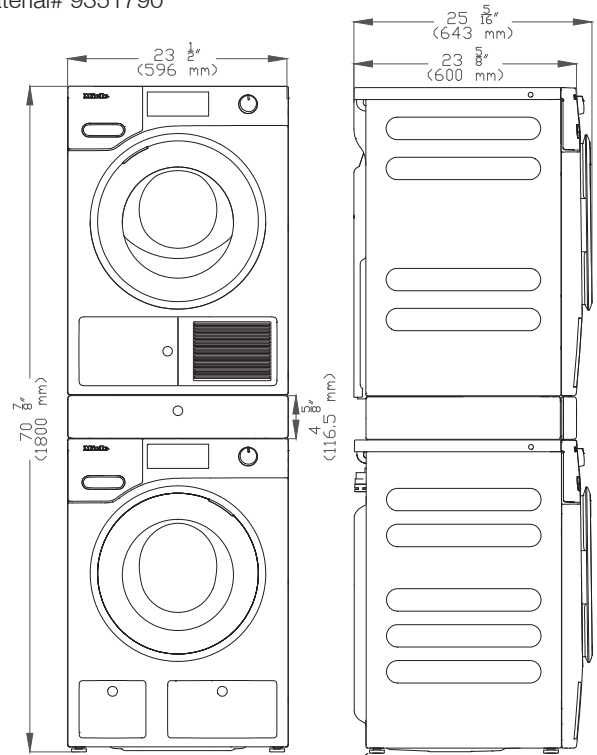

WTS510

Material# 9322300

