

ContourLine
24" Speed Oven

H 6500 BM



ContourLine Speed Oven H 6500 BM



H 6500 BM

Features:

- SensorTronic controls: 5-line TFT display with laterally positioned sensor controls that clearly present menu content
- 19 operating modes
- Rapid Preheat
- Roast probe for perfect roasting results
- MasterChef menu offers over 100 food types to cook to perfection
- Favorites - up to 20 recipes
- 1,000 watt microwave
- Popcorn button
- Minute Plus button - time and power individually programmable
- PerfectClean interior
- Timer
- Sabbath Program
- ComfortSwivel handle moves with the motion of your wrist, creating a more ergonomic feel when opening and closing the oven door



SPECIFICATIONS

H 6500 BM — Item 22650054USA

Overall Unit Width - Excluding Fascia Dimension	22 ¹ / ₁₆ " (560 mm)
Overall Unit Height - Excluding Fascia Dimension	17 ¹ / ₂ " (445 mm)
Overall Unit Depth - Excluding Fascia Dimension	21 ⁵ / ₁₆ " (542 mm)
Oven Door Clearance	12 ⁵ / ₁₆ " (313 mm)
Overall Fascia Dimensions	23 ⁷ / ₁₆ " (595 mm) W x 17 ¹⁵ / ₁₆ " (455 mm) H x 7 ⁷ / ₈ " (22 mm) D

Built-In

Minimum Cabinet Opening Width	22 ¹ / ₁₆ " (561 mm)
Minimum Cabinet Opening Depth	21 ⁵ / ₈ " (550 mm)
Minimum Cabinet Opening Height	17 ³ / ₄ " (450 mm)
Minimum Base Support	125 lbs

Electrical

Electrical Requirements*	120/208-240V, 60Hz, Min, 20A - Max. 30A
Power Cord	Molded NEMA 14-30 plug, 6 ft. (1.8 m)
Electrical Rating	4kW (120/240V), 3kW (120/208V)

Shipping

Shipping Weight	126 lbs
Shipping Dimensions	25 ⁵ / ₈ " W (727 mm) x 24 ¹³ / ₁₆ " (630 mm) H x 27" (686 mm) L

Support

Call Miele	800.843.7231
Miele Website	www.mieleusa.com
20/20 Link	2020technologies.com

* Minimum branch circuit fuse rating should be 20 A and maximum fuse rating must not be greater than 30 A.

PureLine 60cm Speed Oven H 6200 BM



HANDLE DETAILS

All Miele Signature And PureLine
Handle Dimensions

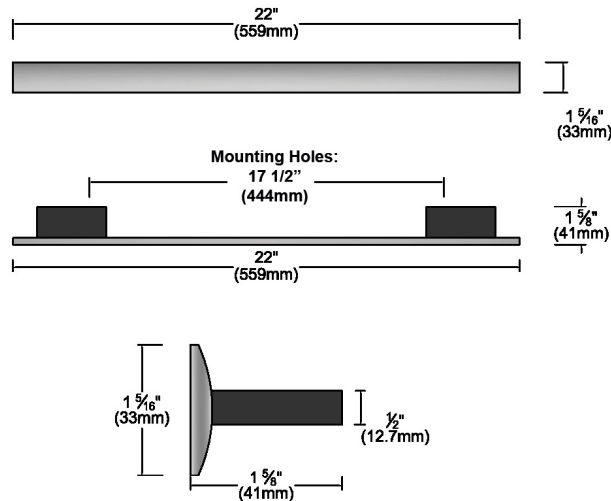

Please note hinges may require adjusting or replacing when changing from a ContourLine Handle to a Pureline or Miele Signature handle.

All ContourLine Handle
Dimensions

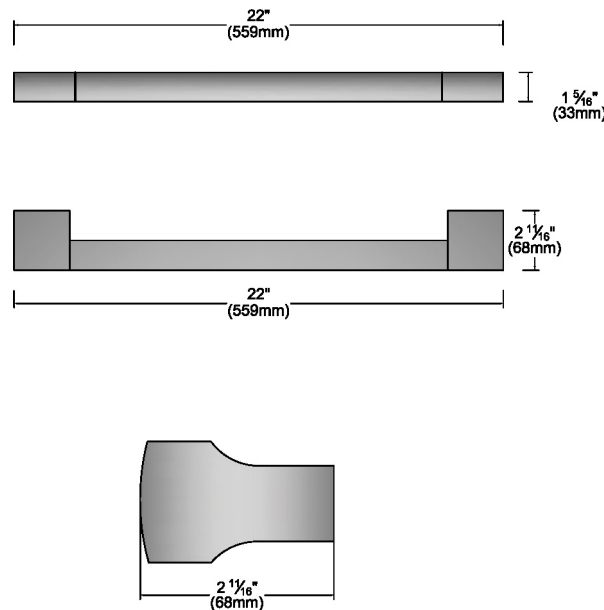

Please note hinges may require adjusting or replacing when changing from a Pureline or Miele Signature handle to a ContourLine Handle.

ContourLine Speed Oven H 6500 BM



PRODUCT VIEWS

Fascia

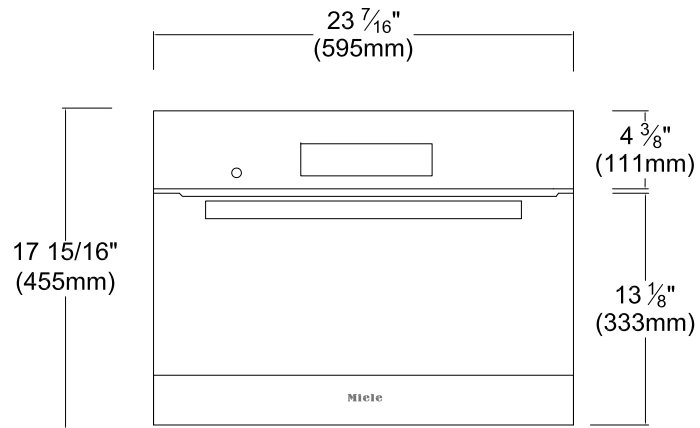

Top View

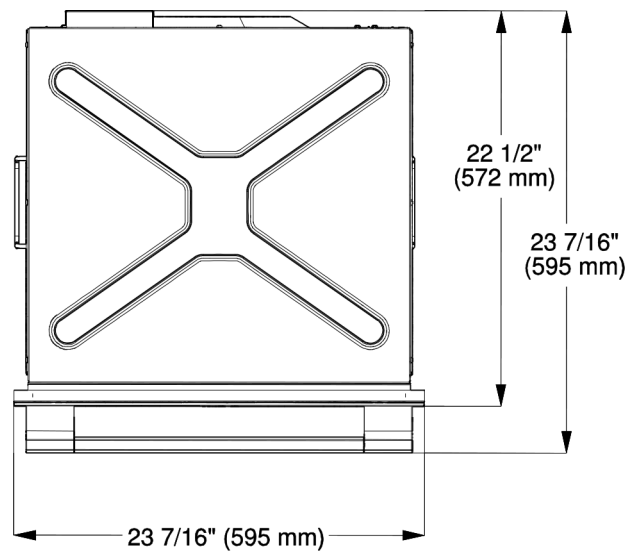

ContourLine Speed Oven H 6500 BM



PRODUCT VIEWS

Rear View

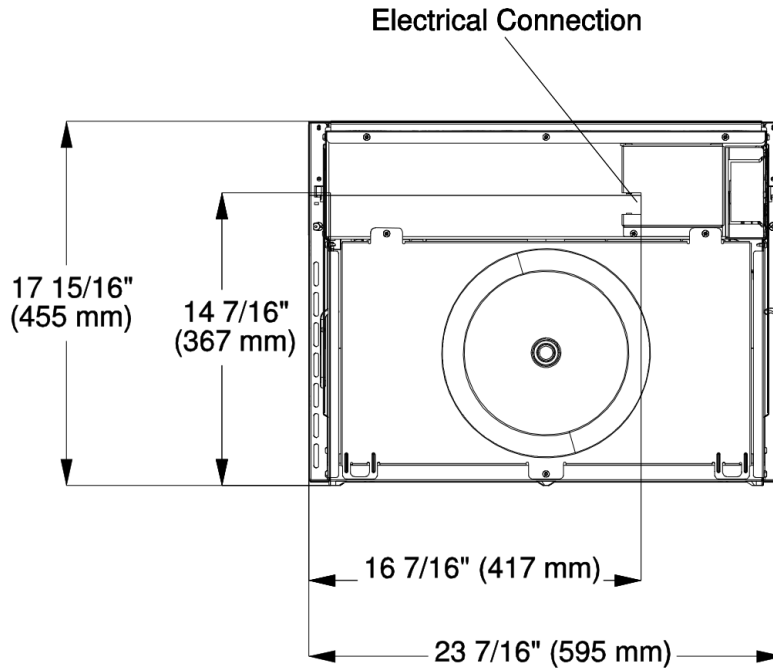

Side View

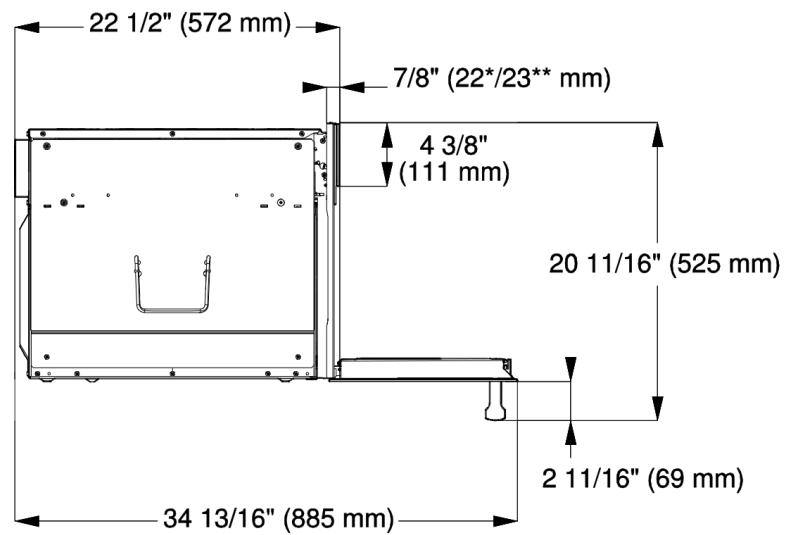

* Oven with glass frc
** Oven with metal fr

ContourLine Speed Oven H 6500 BM



INSTALLATION SPECIFICATIONS

Door Swing Details

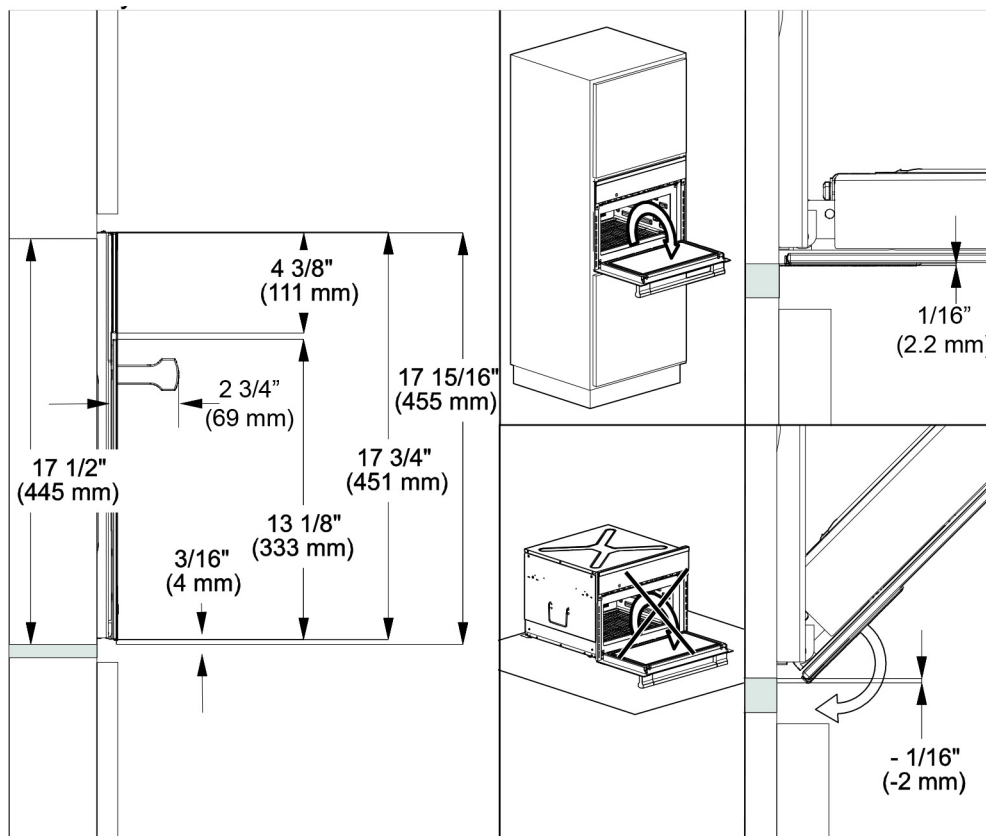

ContourLine Speed Oven H 6500 BM



INSTALLATION SPECIFICATIONS

Install in Tall Cabinet

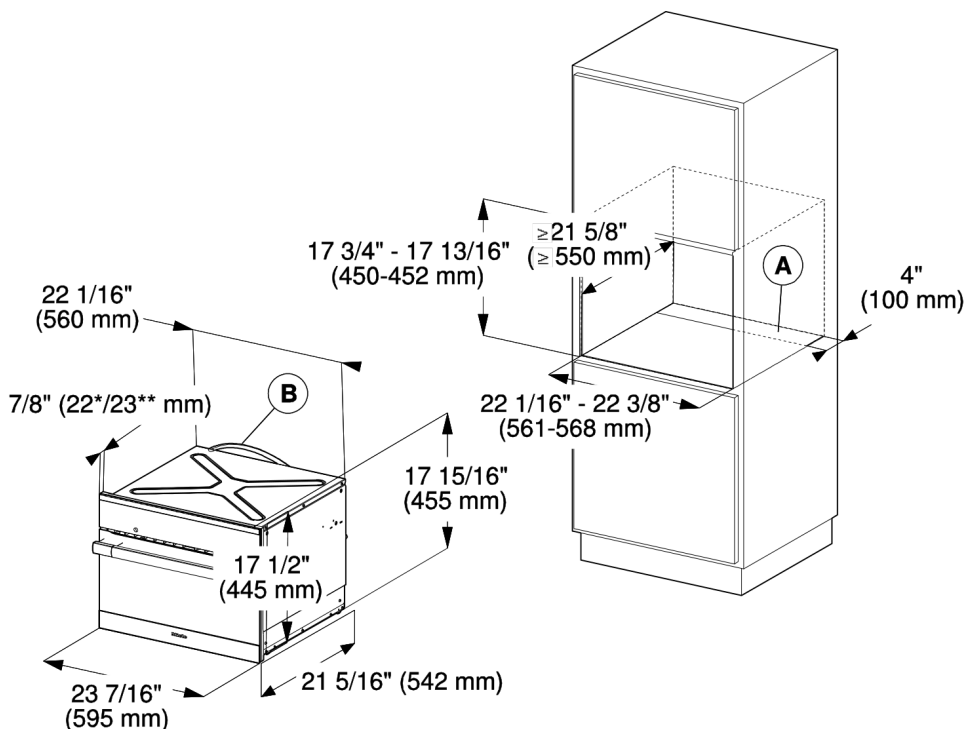

- Ⓐ Cut-out (4" x 22" / 100 mm x 560 mm) in the bottom of the cabinet for power cord and ventilation
- Ⓑ Power cord with plug

* Oven with glass front
** Oven with metal front

Undercounter Installation With Framed Cabinet

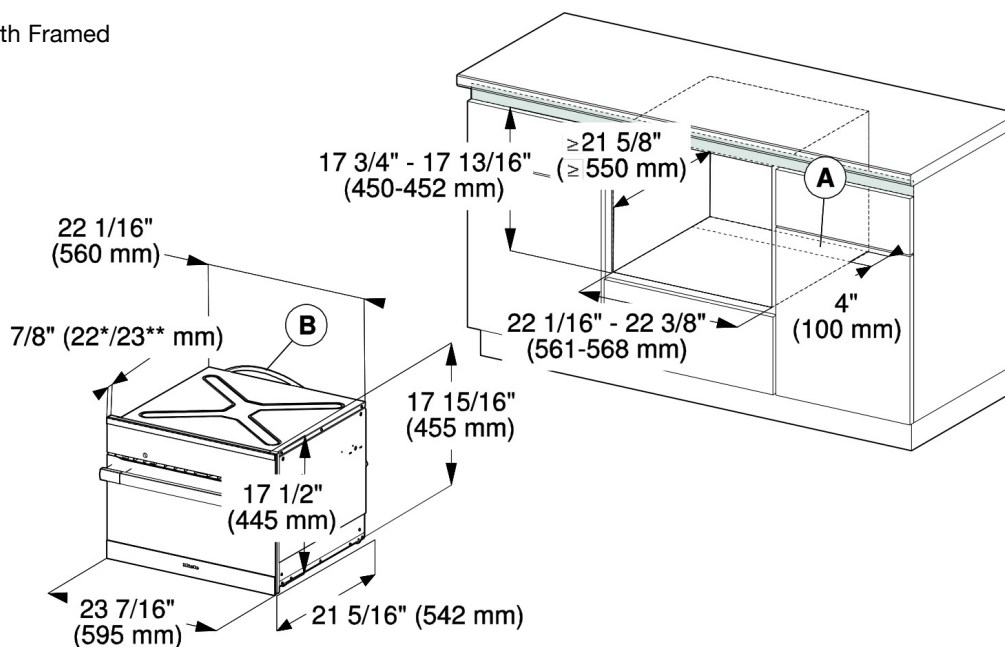

- Ⓐ Cut-out (4" x 22" / 100 mm x 560 mm) in the bottom of the cabinet for power cord and ventilation
- Ⓑ Power cord with plug

* Oven with glass front
** Oven with metal front

ContourLine Speed Oven H 6500 BM



INSTALLATION SPECIFICATIONS

Undercounter Installation Against CounterTop

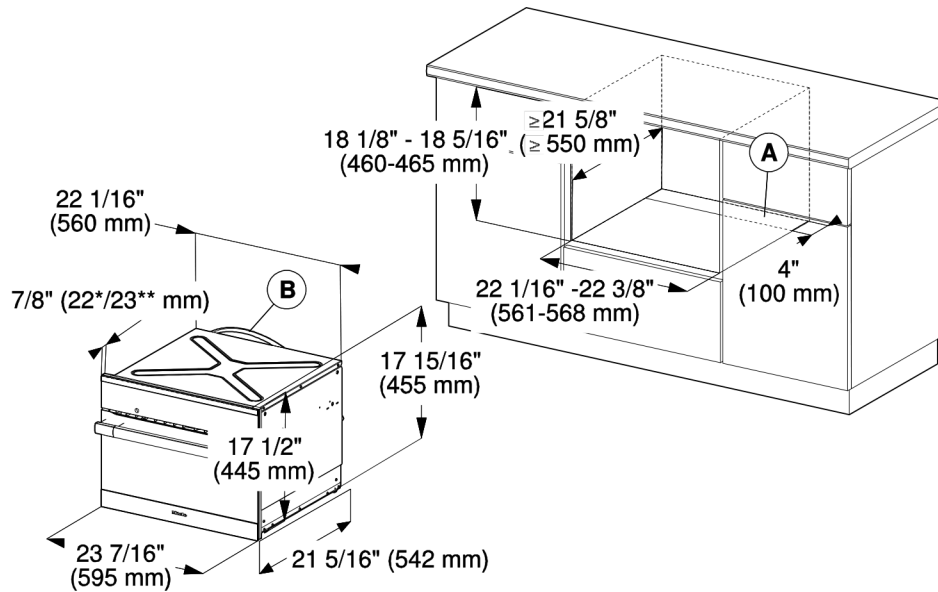

- Ⓐ Cut-out (4" x 22" / 100 mm x 560 mm) in the bottom of the cabinet for power cord and ventilation
- Ⓑ Power cord with plug

* Oven with glass front
** Oven with metal front

Under Counter Install Against Counter Top
Front View

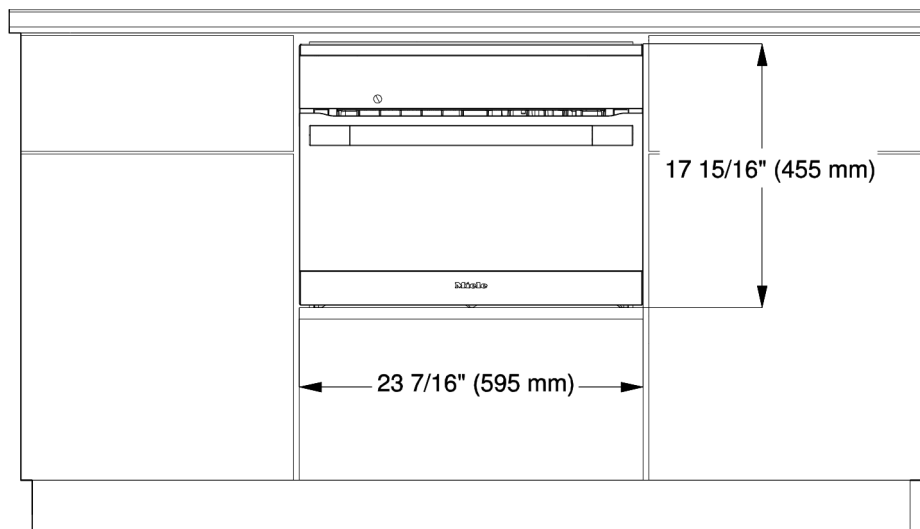

ContourLine Speed Oven H 6500 BM



INSTALLATION SPECIFICATIONS

Stacked With 24 Inch Oven Installation

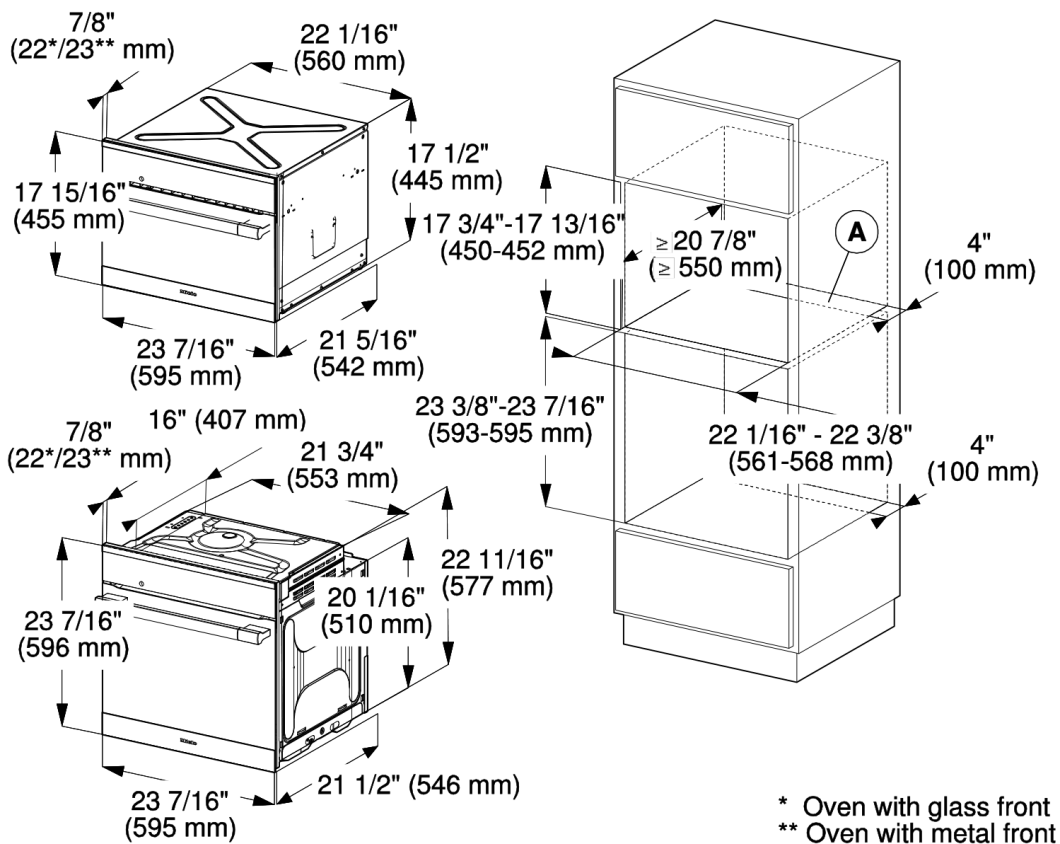

Ⓐ Cut-out ($4'' \times 22''$ / $100 \text{ mm} \times 560 \text{ mm}$) in the bottom of the cabinet for power cord and ventilation